

05032000 - LT-S VDI40 ER32F H67 TW-TZ

Type	LT-S Tool holder straight
Mounting	VDI 40
Tool output	Collet nut ER 32 F - internal nut
Coolant	External coolant
Direction of rotation	r1 ↻ r2 ↻
Max speed [rpm]	6000
Max torque [Nm]	63
Ratio	1:1
H [mm]	67
Accessories	
Notes	N.A.
Mounting tips	Not suitable for every application, please check

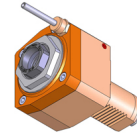

IMPORTANT: CHECK CAREFULLY THE VDI ORIENTATION

Always check live tool dimensions on the turret

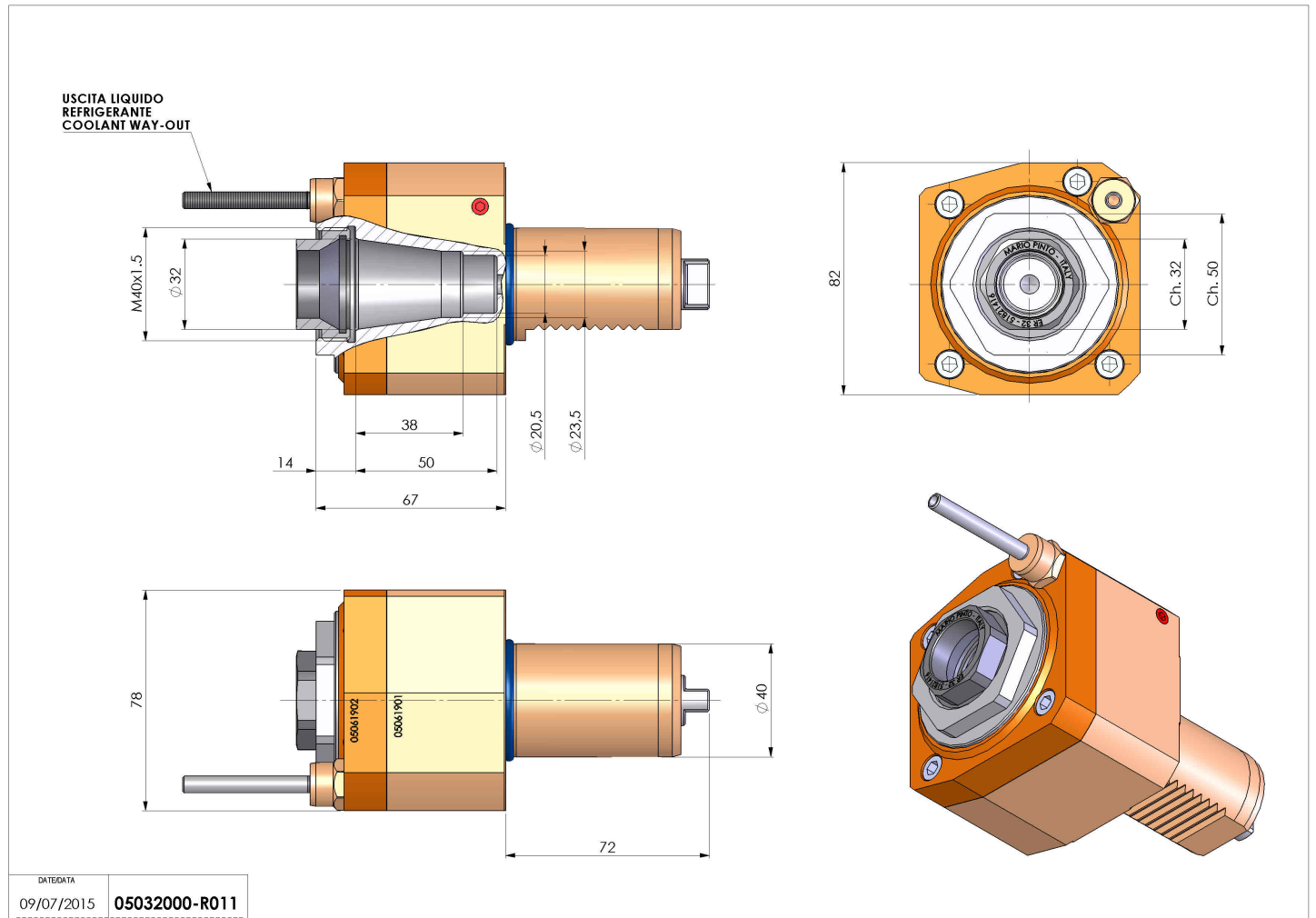

DATE/DATE	09/07/2015
05032000-R011	

Subject to technical changes

05031900 - LT-T VDI40 ER25 H71-165 TW-TZ

Type	LT-T Tool holder tiltable
Mounting	VDI 40
Tool output	Collet nut ER 25
Coolant	External coolant
Direction of rotation	r1 ↻ r2 ↻
Max speed [rpm]	3000
Max torque [Nm]	20
Ratio	1:1
H [mm]	71-165
Accessories	N.A.
Notes	N.A.
Mounting tips	Not suitable for every application, please check

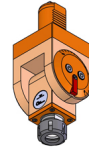

IMPORTANT: CHECK CAREFULLY THE VDI ORIENTATION

Always check live tool dimensions on the turret

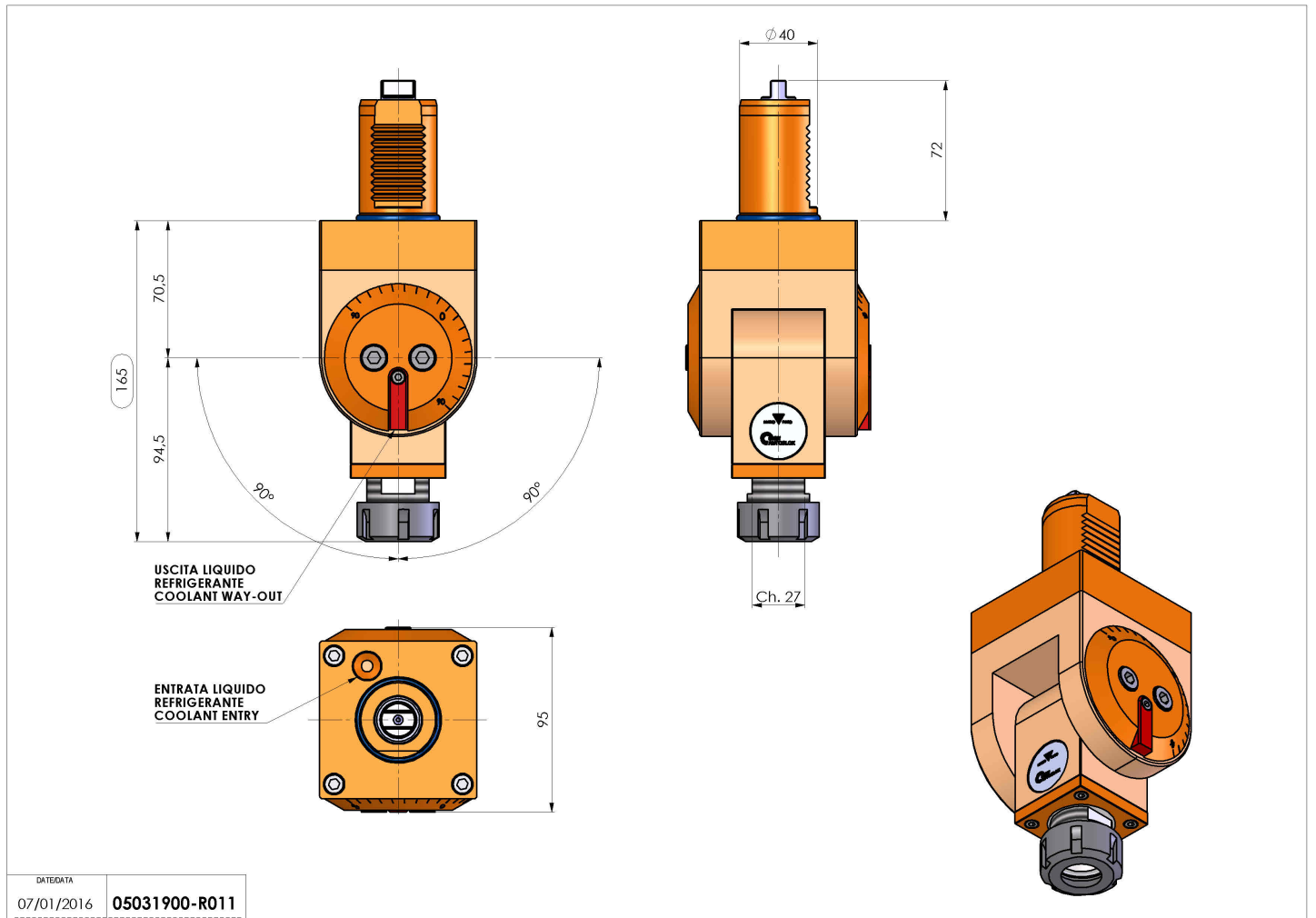

Subject to technical changes

DATE/DATE: 07/01/2016
 05031900-R011

