

05060800 - LT-A VDI40 ER32F R H70

Type	LT-A Tool holder angle 90°
Mounting	VDI 40
Tool output	Collet nut ER 32 F - internal nut
Coolant	Internal coolant
Direction of rotation	r1 ↻ r2 ↻
Max speed [rpm]	6000
Max torque [Nm]	63
Ratio	1:1
H [mm]	70
H1 [mm]	38
Accessories	N.A.
Notes	N.A.
Mounting tips	Not suitable for every application, please check

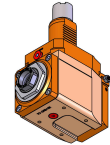

IMPORTANT: CHECK CAREFULLY THE VDI ORIENTATION

Always check live tool dimensions on the turret

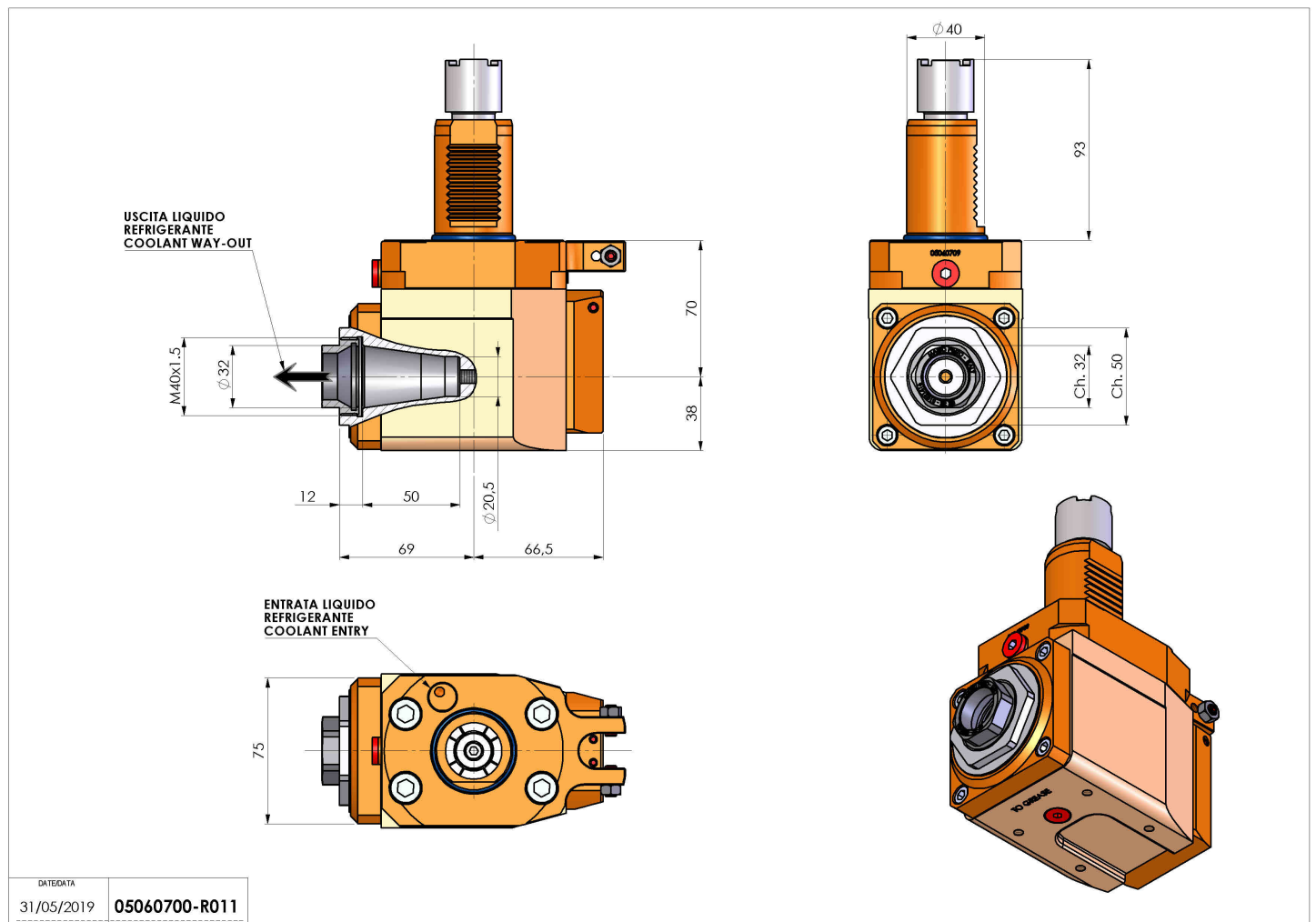

DATE/ATA	05060700-R011
31/05/2019	

Subject to technical changes

05063000 - LT-T VDI40 ER16F R H63-132 OK

Type	LT-T Tool holder tiltable
Mounting	VDI 40
Tool output	Collet nut ER 16 F - internal nut
Coolant	External coolant
Direction of rotation	r1 ↻ r2 ↻
Max speed [rpm]	6000
Max torque [Nm]	10
Ratio	1:1
H [mm]	63-132
Accessories	N.A.
Notes	N.A.
Mounting tips	Not suitable for every application, please check

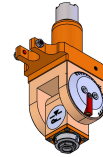

IMPORTANT: CHECK CAREFULLY THE VDI ORIENTATION

Always check live tool dimensions on the turret

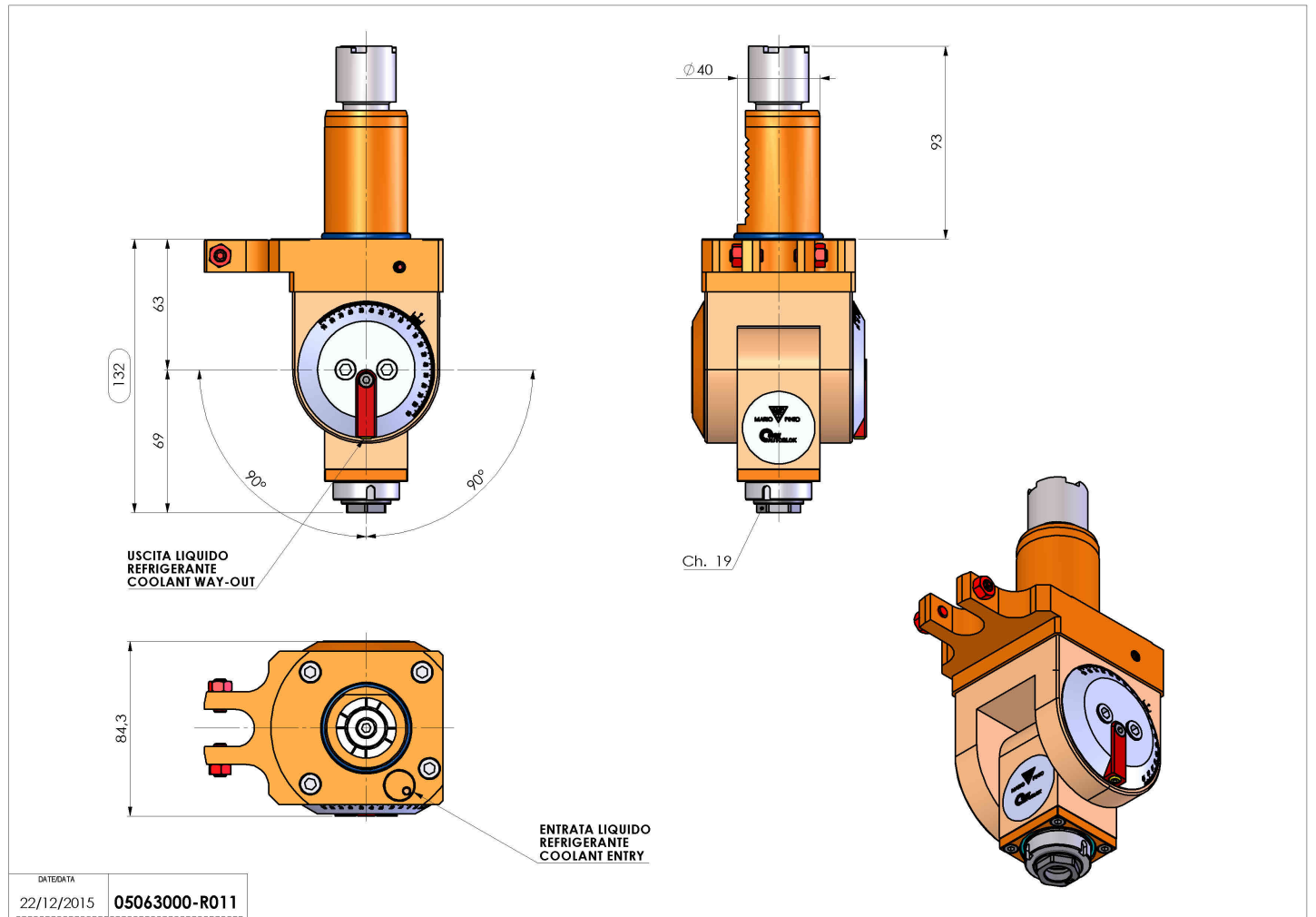

Subject to technical changes

05266000 - LT-S VDI40 ER32 H130 OK

Type	LT-S Tool holder straight
Mounting	VDI 40
Tool output	Collet nut ER 32
Coolant	External coolant
Direction of rotation	r1 ↻ r2 ↻
Max speed [rpm]	6000
Max torque [Nm]	63
Ratio	1:1
H [mm]	130
Accessories	
Notes	N.A.
Mounting tips	Not suitable for every application, please check

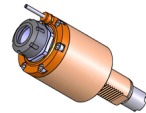

IMPORTANT: CHECK CAREFULLY THE VDI ORIENTATION

Always check live tool dimensions on the turret

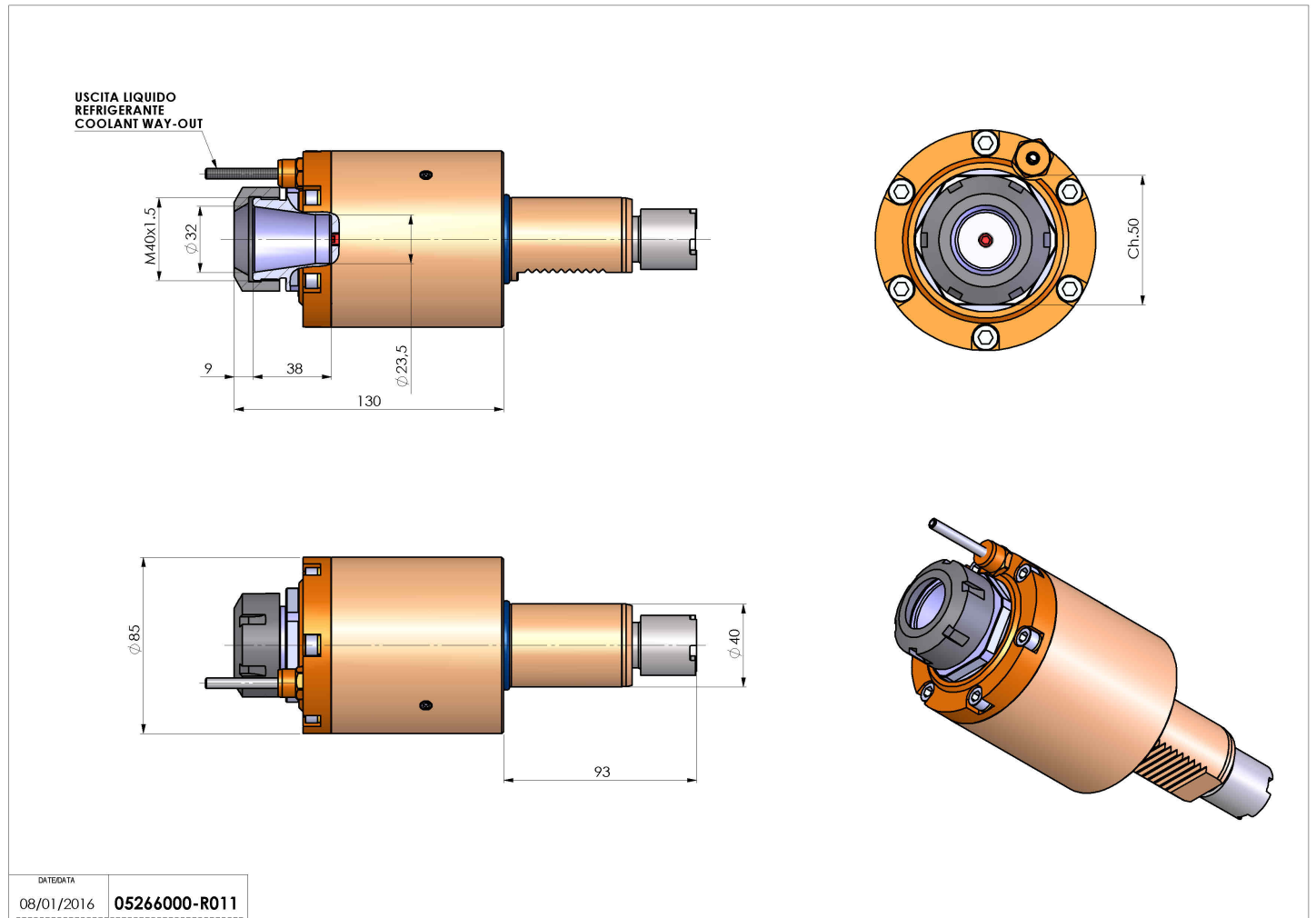

DATE/DATE	08/01/2016	05266000-R011
-----------	------------	---------------

Subject to technical changes