

## 05055000 - LT-S VDI40 ER32F G60 OFS50 MZ

Type	LT-S OFS Tool holder straight offset
Mounting	VDI 40
Tool output	Collet nut ER 32 F - internal nut
Coolant	External coolant
Offset [mm]	50
Direction of rotation	r1 ↻ r2 ↻
Max speed [rpm]	6000
Max torque [Nm]	63
Ratio	1:1
H [mm]	95
Accessories	N.A.
Notes	N.A.
Mounting tips	Not suitable for every application, please check

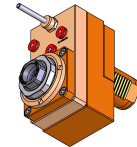

**IMPORTANT: CHECK CAREFULLY THE VDI ORIENTATION**

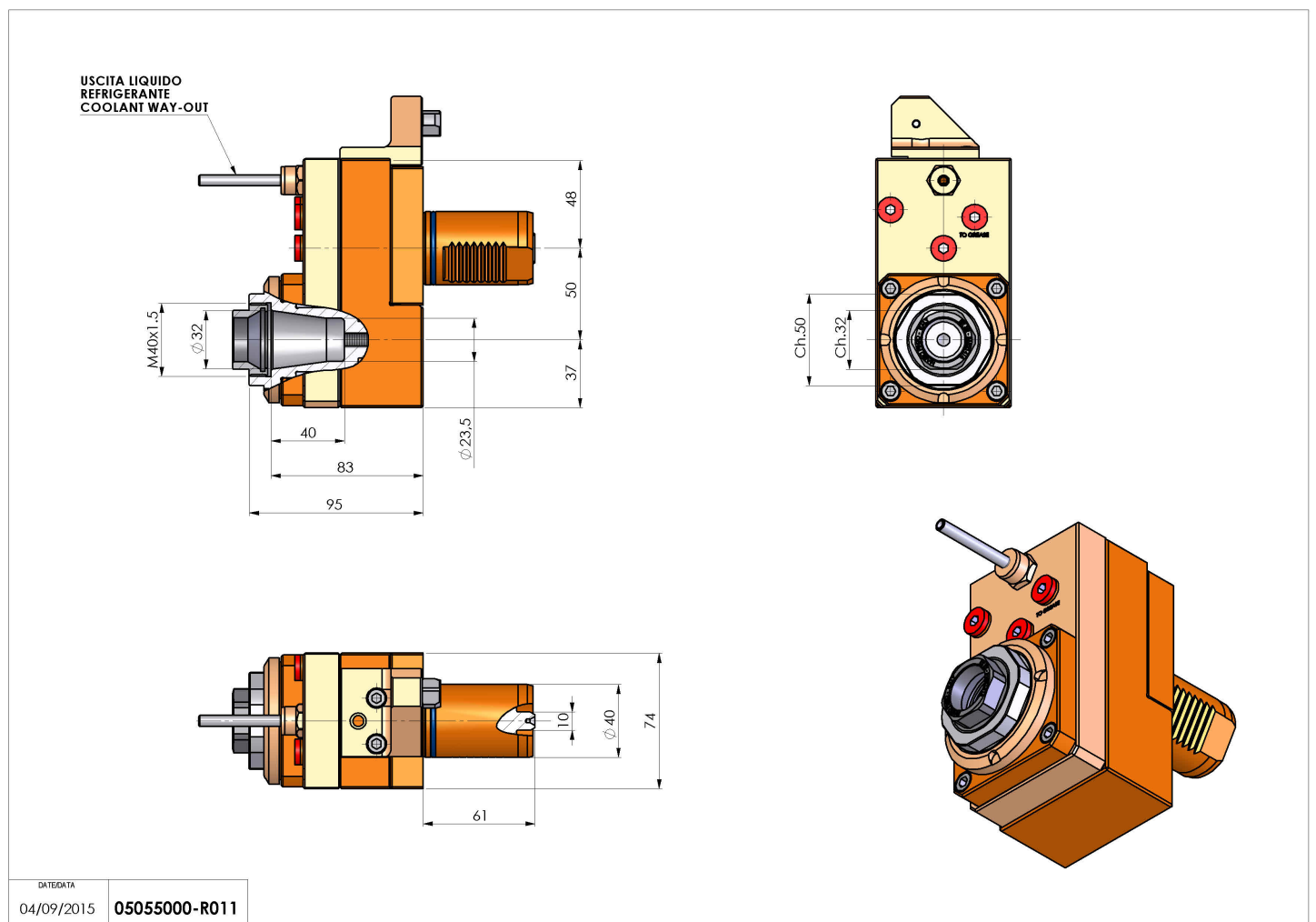

Always check live tool dimensions on the turret



DATE/DATE	04/09/2015
	05055000-R011

Subject to technical changes

# 05055100 - LT-A VDI40 ER32F G60 L H100 MZ

<b>Type</b>	LT-A Tool holder angle 90°
<b>Mounting</b>	VDI 40
<b>Tool output</b>	Collet nut ER 32 F - internal nut
<b>Coolant</b>	External coolant
<b>Direction of rotation</b>	r1  r2 
<b>Max speed [rpm]</b>	6000
<b>Max torque [Nm]</b>	63
<b>Ratio</b>	1:1
<b>H [mm]</b>	100
<b>H1 [mm]</b>	38
<b>Accessories</b>	N.A.
<b>Notes</b>	N.A.

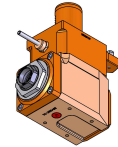

**Mounting tips** Not suitable for every application, please check

**IMPORTANT: CHECK CAREFULLY THE VDI ORIENTATION**

Always check live tool dimensions on the turret

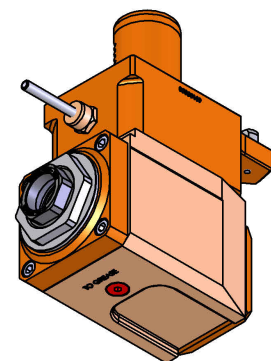
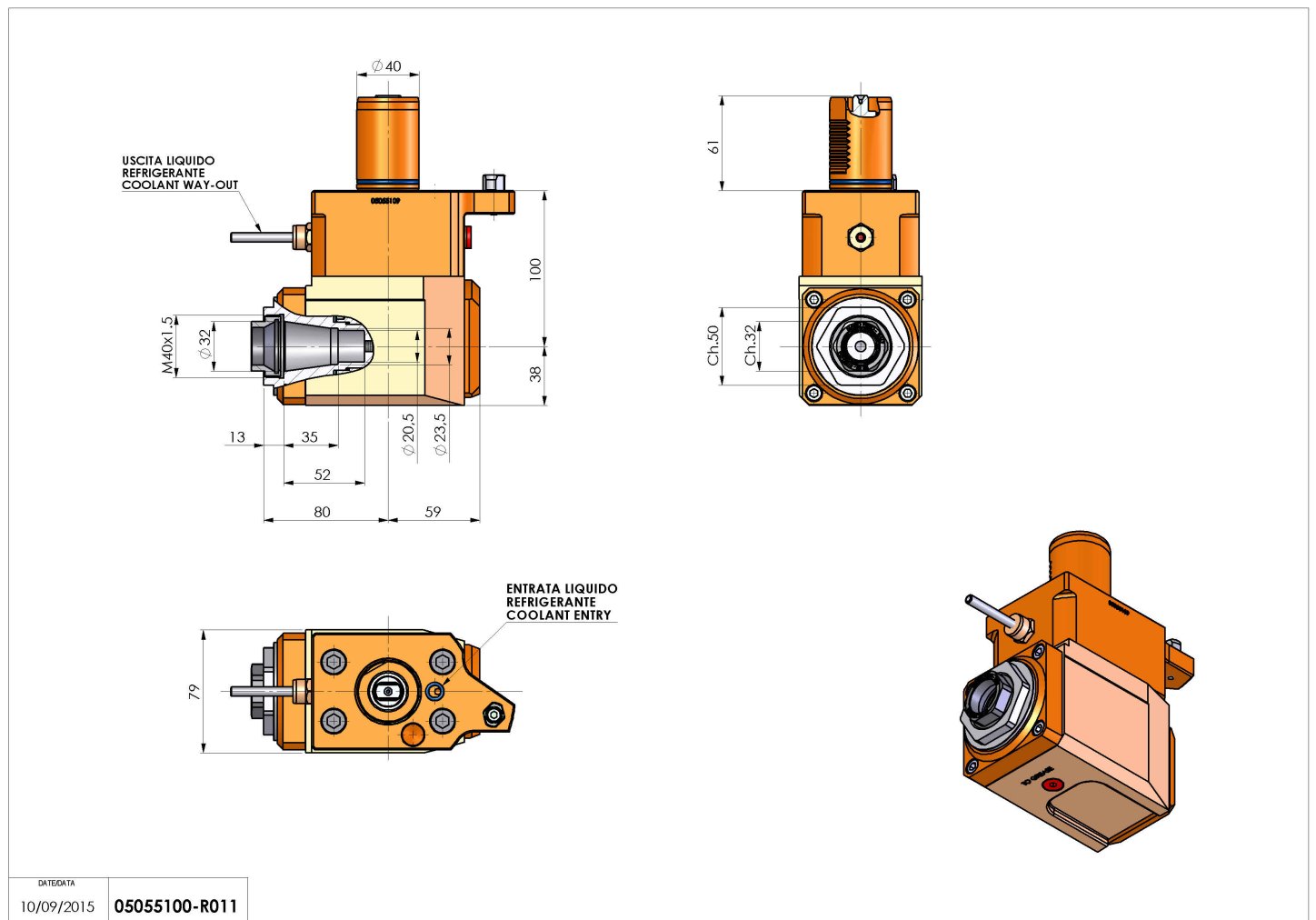

DATE/DATE	10/09/2015	05055100-R011
-----------	------------	---------------

Subject to technical changes

# 05055900 - LT-T VDI40 ER16F H63-132 G60MZ

<b>Type</b>	LT-T Tool holder tiltable
<b>Mounting</b>	VDI 40
<b>Tool output</b>	Collet nut ER 16 F - internal nut
<b>Coolant</b>	External coolant
<b>Direction of rotation</b>	r1 ↻ r2 ↻
<b>Max speed [rpm]</b>	6000
<b>Max torque [Nm]</b>	10
<b>Ratio</b>	1:1
<b>H [mm]</b>	63-132
<b>Accessories</b>	N.A.
<b>Notes</b>	N.A.
<b>Mounting tips</b>	Not suitable for every application, please check

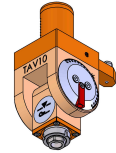

**IMPORTANT: CHECK CAREFULLY THE VDI ORIENTATION**

Always check live tool dimensions on the turret

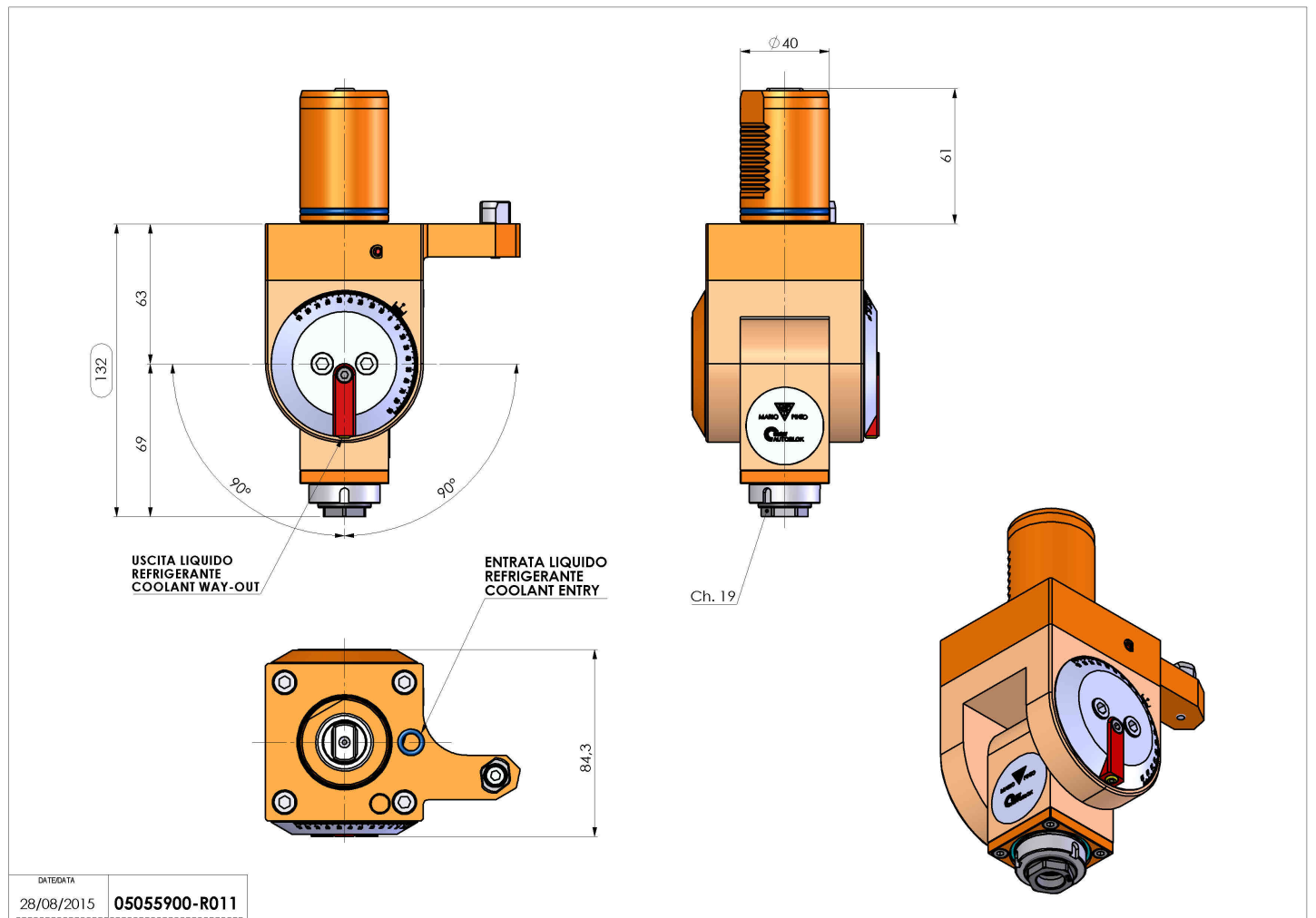

DATE DATA	05055900-R011
28/08/2015	

Subject to technical changes