

05110100 - LT-S VDI40 ER32F H53 HA

Type	LT-S Tool holder straight
Mounting	VDI 40
Tool output	Collet nut ER 32 F - internal nut
Coolant	External coolant
Direction of rotation	r1 ↻ r2 ↻
Max speed [rpm]	6000
Max torque [Nm]	63
Ratio	1:1
H [mm]	67
Accessories	
Notes	N.A.
Mounting tips	Not suitable for every application, please check

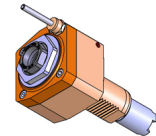

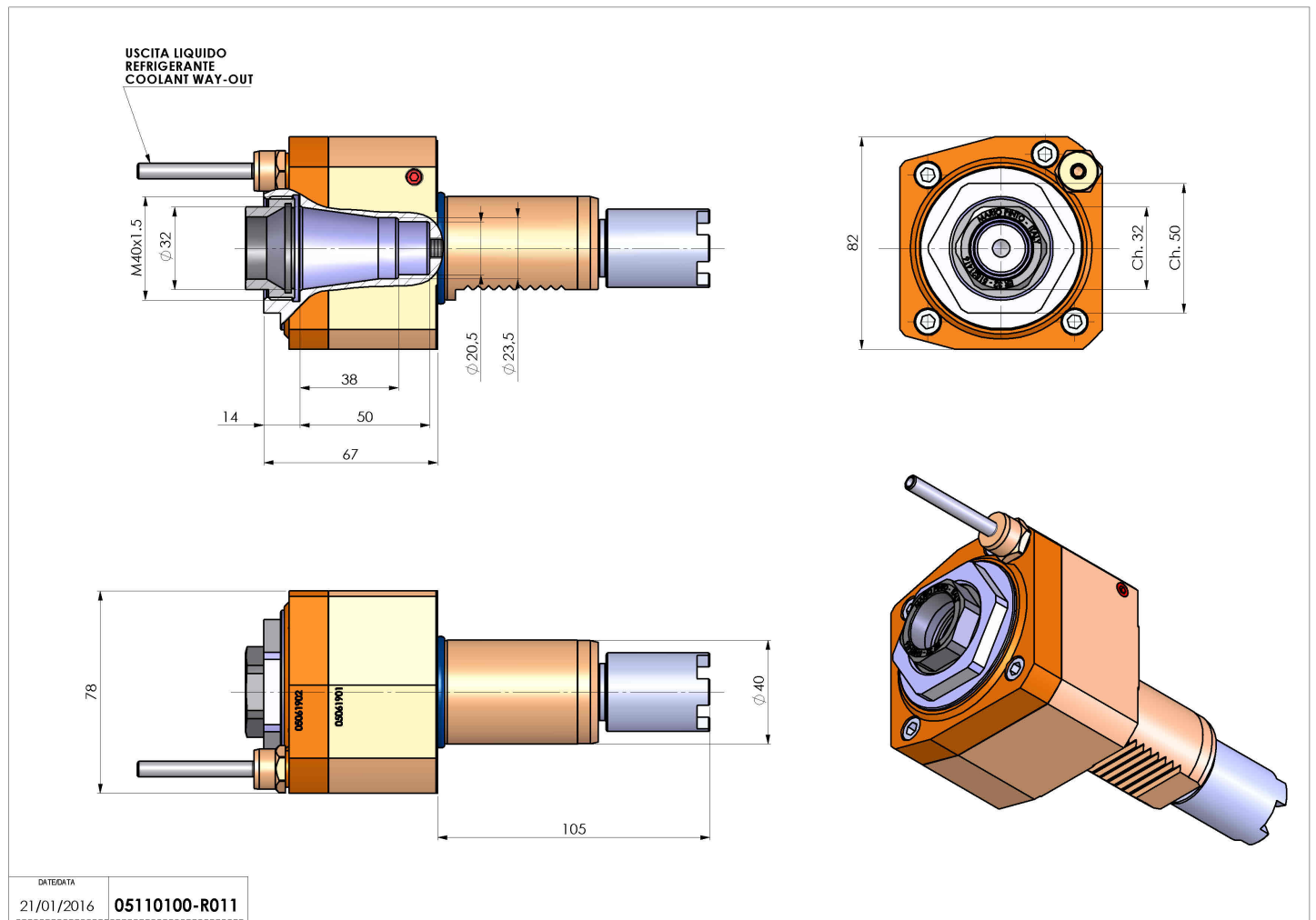

IMPORTANT: CHECK CAREFULLY THE VDI ORIENTATION

Always check live tool dimensions on the turret



Subject to technical changes

05110200 - LT-A VDI40 ER32F R H75 HA

Type	LT-A Tool holder angle 90°
Mounting	VDI 40
Tool output	Collet nut ER 32 F - internal nut
Coolant	External coolant
Direction of rotation	r1  r2 
Max speed [rpm]	6000
Max torque [Nm]	63
Ratio	1:1
H [mm]	75
H1 [mm]	38
Accessories	N.A.
Notes	N.A.
Mounting tips	Not suitable for every application, please check

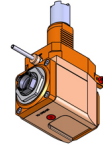

IMPORTANT: CHECK CAREFULLY THE VDI ORIENTATION

Always check live tool dimensions on the turret

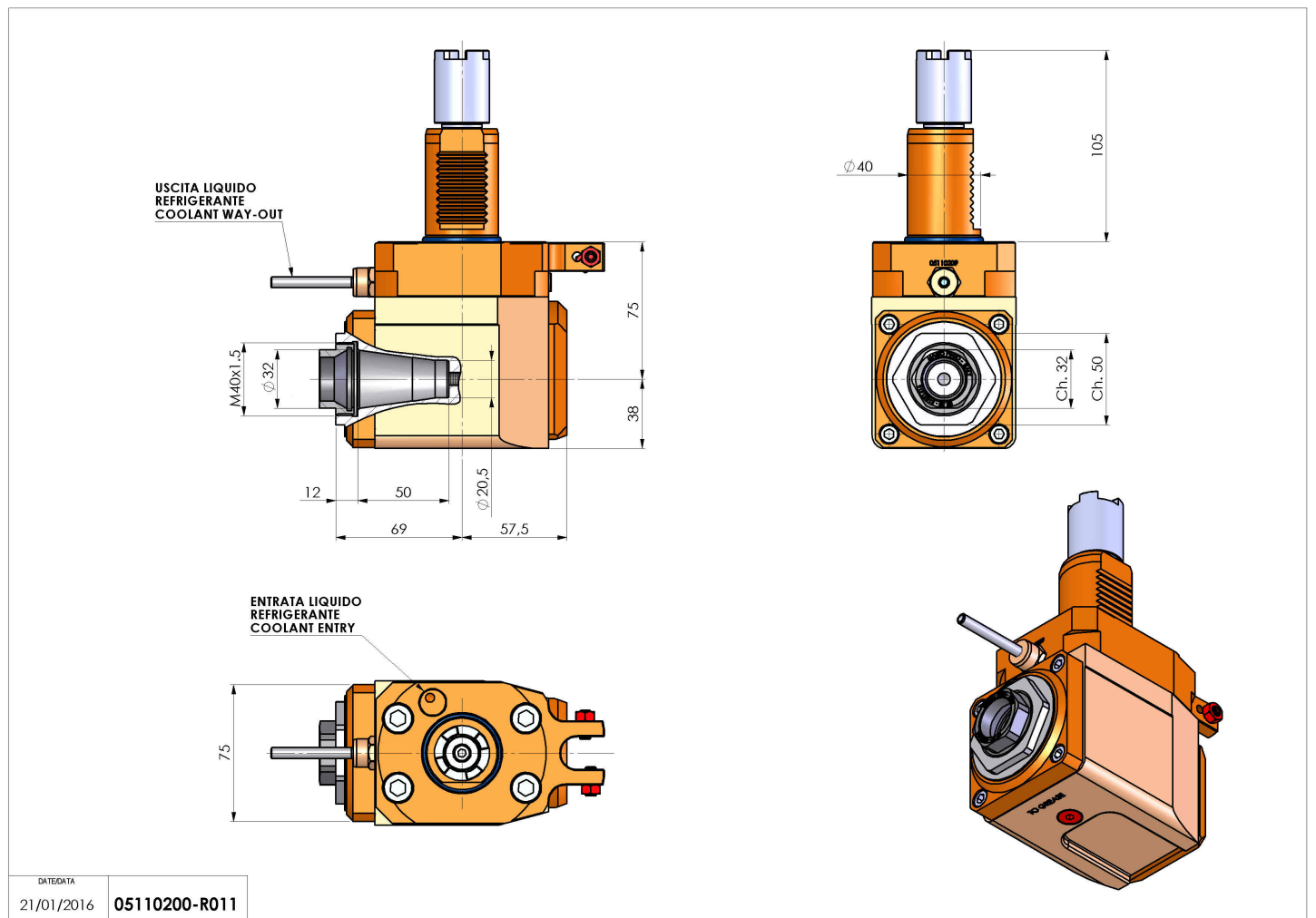

DATE/DATE	05110200-R011
21/01/2016	

Subject to technical changes

05114000 - LT-S VDI40 ER32F H74 130 HA

Type	LT-S Tool holder straight
Mounting	VDI 40
Tool output	Collet nut ER 32 F - internal nut
Coolant	External coolant
Direction of rotation	r1 ↻ r2 ↻
Max speed [rpm]	6000
Max torque [Nm]	63
Ratio	1:1
H [mm]	74
Accessories	
Notes	N.A.
Mounting tips	Not suitable for every application, please check

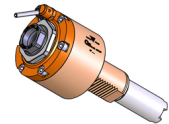

IMPORTANT: CHECK CAREFULLY THE VDI ORIENTATION

Always check live tool dimensions on the turret

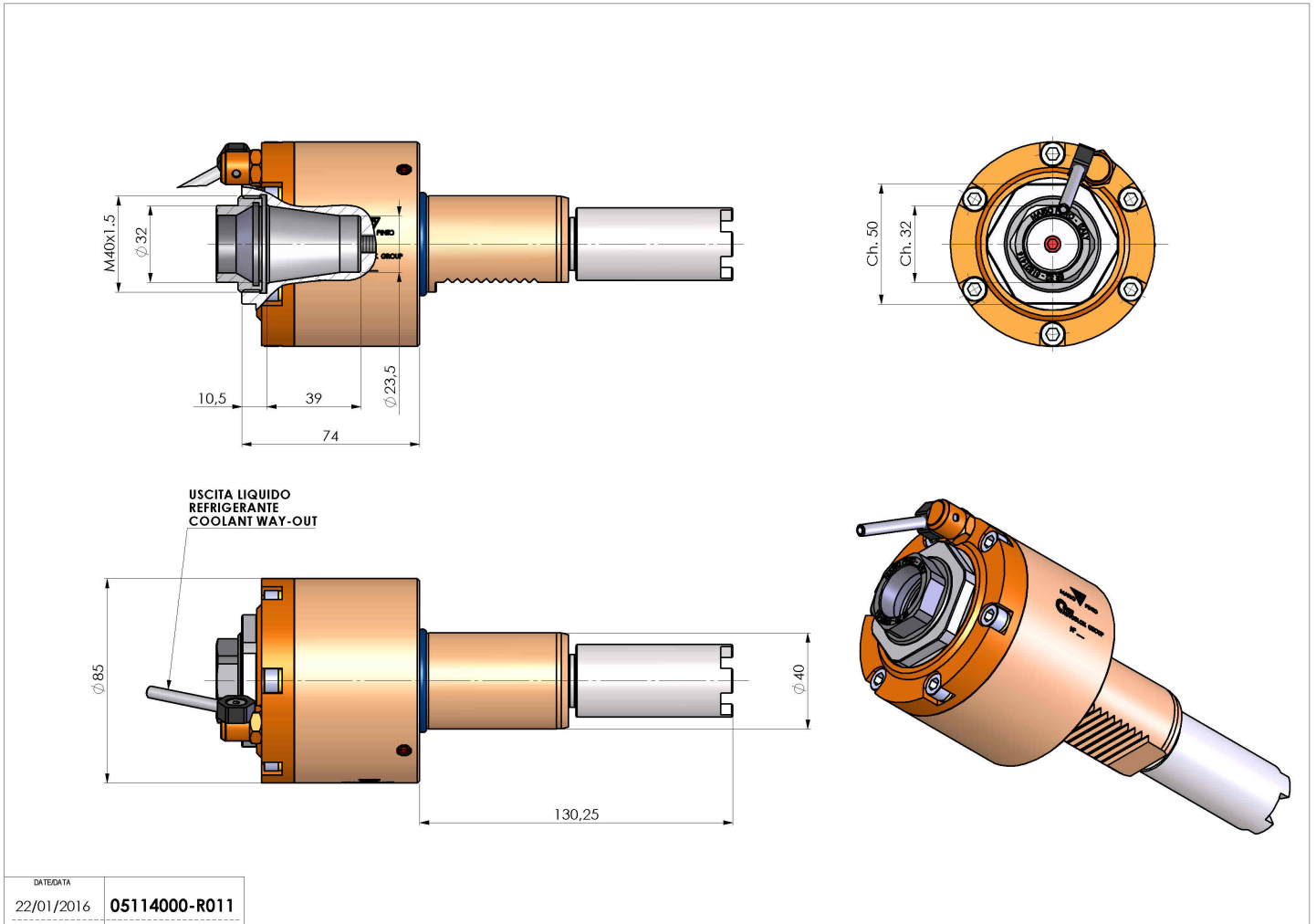

DATE/DATE	22/01/2016
	05114000-R011

Subject to technical changes

05114600 - LT-A VDI40 ER32F H75 130 HA

Type	LT-A Tool holder angle 90°
Mounting	VDI 40
Tool output	Collet nut ER 32 F - internal nut
Coolant	External coolant
Direction of rotation	r1 ↻ r2 ↻
Max speed [rpm]	6000
Max torque [Nm]	63
Ratio	1:1
H [mm]	75
H1 [mm]	38
Accessories	N.A.
Notes	N.A.
Mounting tips	Not suitable for every application, please check

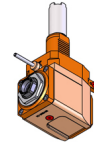

IMPORTANT: CHECK CAREFULLY THE VDI ORIENTATION

Always check live tool dimensions on the turret

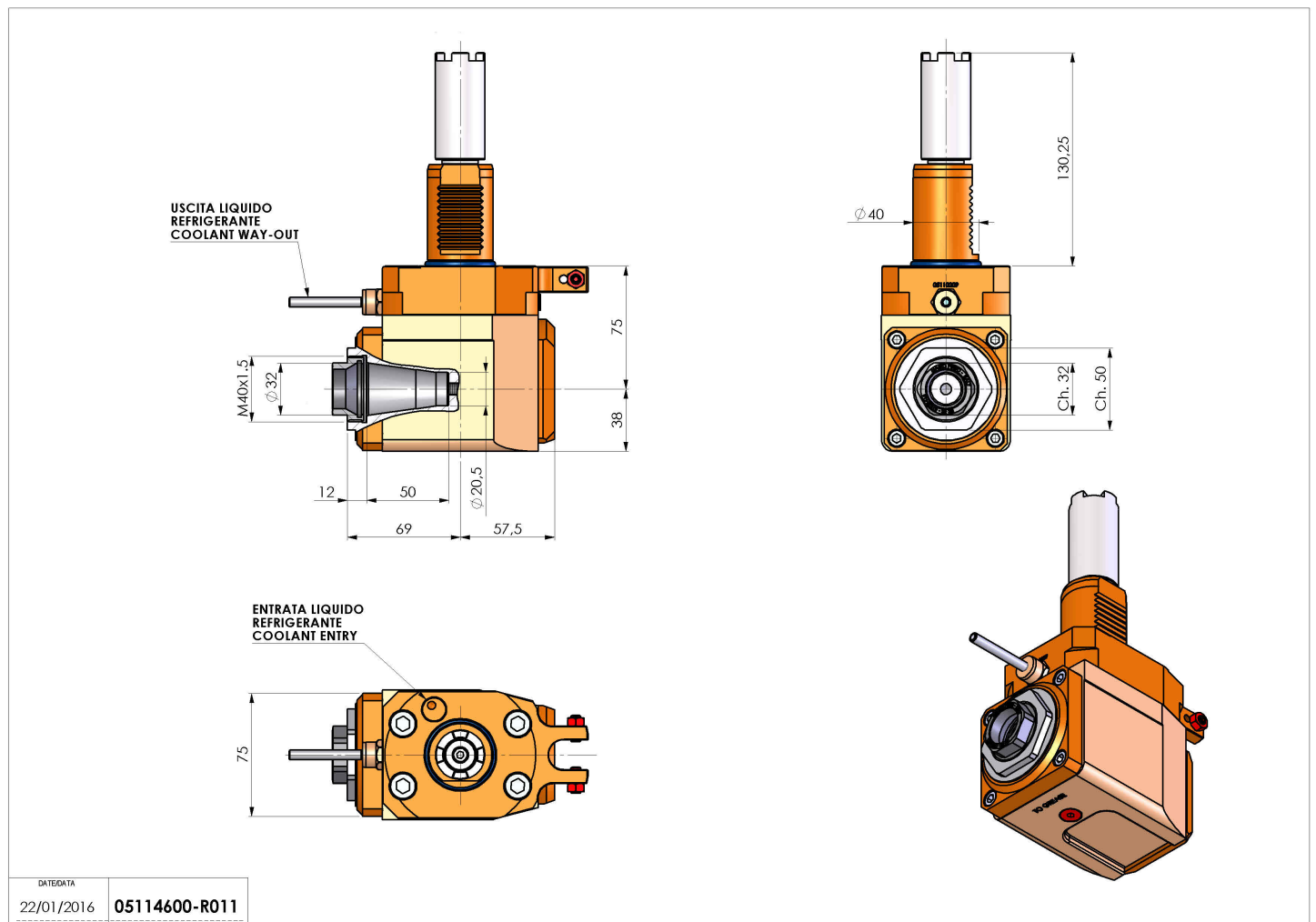

DATE/DATE	22/01/2016
05114600-R011	

Subject to technical changes