

05112000 - LT-S VDI40 ER32F H74 117 HA

Type	LT-S Tool holder straight
Mounting	VDI 40
Tool output	Collet nut ER 32 F - internal nut
Coolant	External coolant
Direction of rotation	r1 r2
Max speed [rpm]	6000
Max torque [Nm]	63
Ratio	1:1
H [mm]	74
Accessories	
Notes	N.A.
Mounting tips	Not suitable for every application, please check

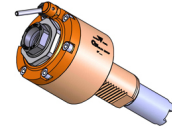

IMPORTANT: CHECK CAREFULLY THE VDI ORIENTATION

Always check live tool dimensions on the turret



DATE/DATE

21/01/2016

05112000-R011

Subject to technical changes

05112300 - LT-A VDI40 ER32F H75 117 HA

Type	LT-A Tool holder angle 90°
Mounting	VDI 40
Tool output	Collet nut ER 32 F - internal nut
Coolant	External coolant
Direction of rotation	r1  r2 
Max speed [rpm]	6000
Max torque [Nm]	63
Ratio	1:1
H [mm]	75
H1 [mm]	38
Accessories	N.A.
Notes	N.A.
Mounting tips	Not suitable for every application, please check

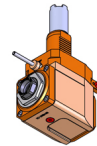

IMPORTANT: CHECK CAREFULLY THE VDI ORIENTATION

Always check live tool dimensions on the turret

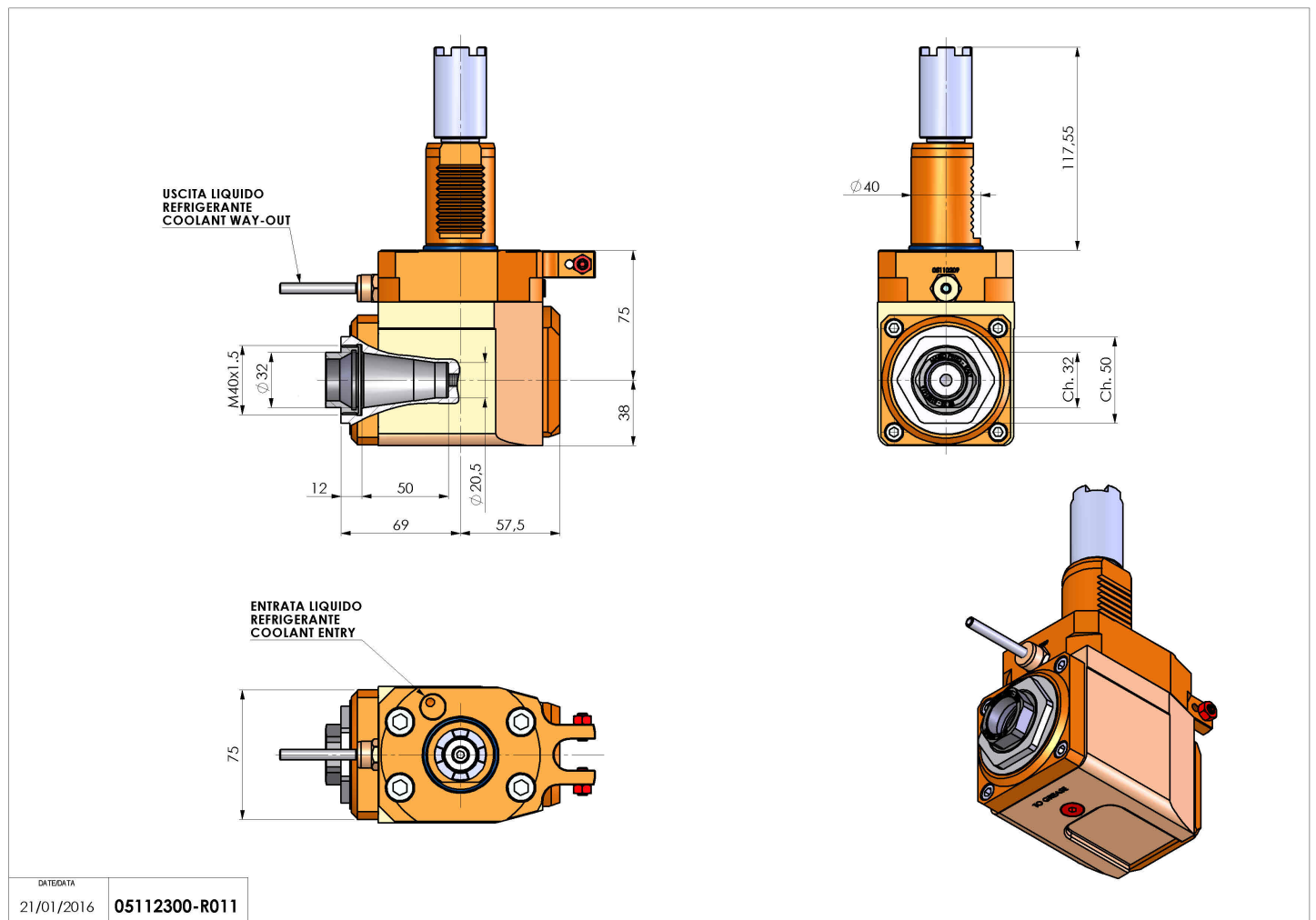

DATE/ATA	05112300-R011
----------	---------------

Subject to technical changes