

05220100 - LT-S VDI30ER25F H66 DIN5480 SA

Type	LT-S Tool holder straight
Mounting	VDI 30
Tool output	Collet nut ER 25 F - internal nut
Coolant	External coolant
Direction of rotation	r1 r2
Max speed [rpm]	6000
Max torque [Nm]	40
Ratio	1:1
H [mm]	65,5
Accessories	
Notes	N.A.
Mounting tips	Not suitable for every application, please check

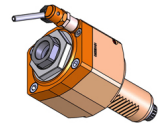

IMPORTANT: CHECK CAREFULLY THE VDI ORIENTATION

Always check live tool dimensions on the turret

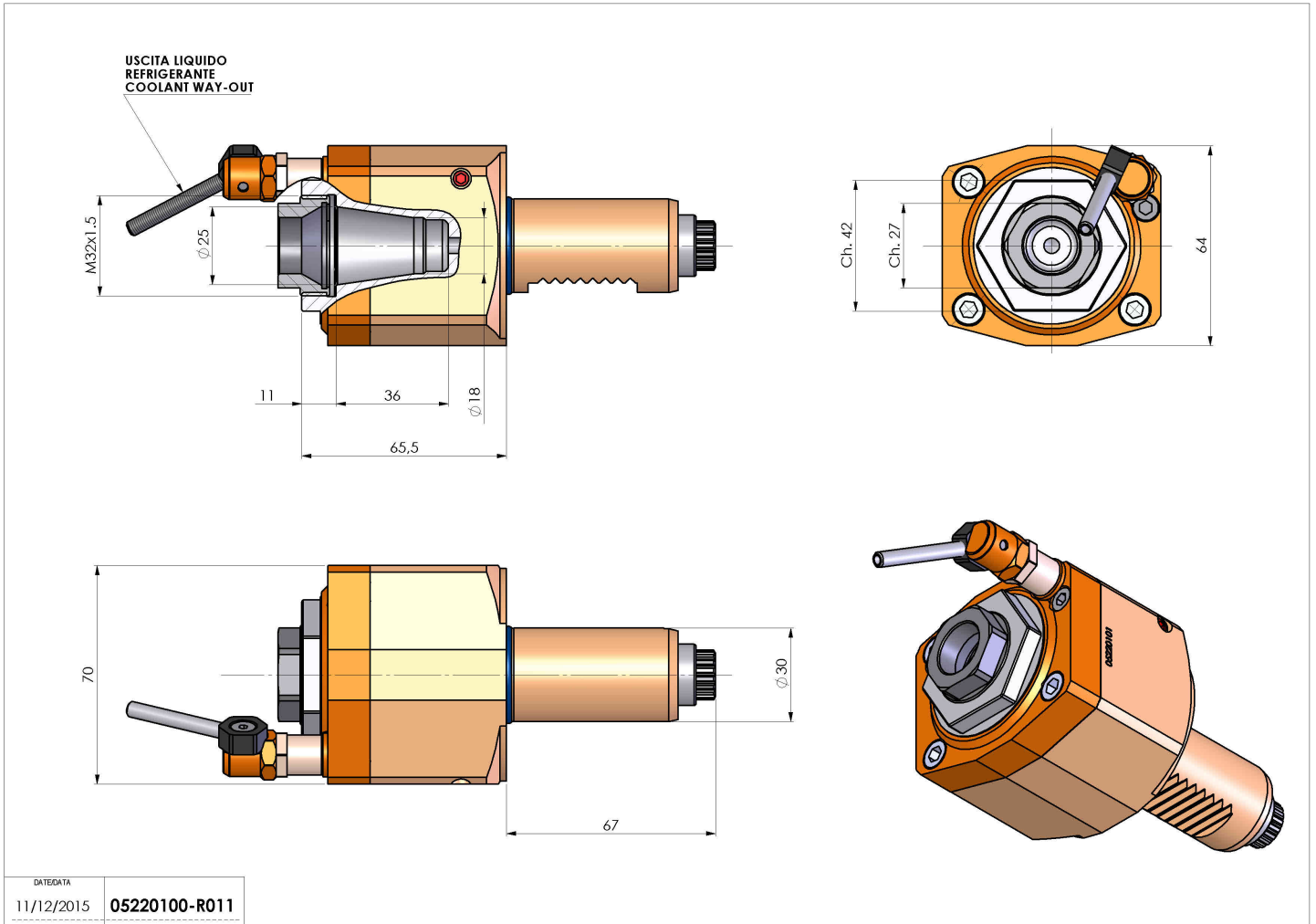

DATE/DATE	11/12/2015	05220100-R011
-----------	------------	---------------

Subject to technical changes

05220200 - LT-S VDI30 ER25 H112 DIN5480SA

Type	LT-S Tool holder straight
Mounting	VDI 30
Tool output	Collet nut ER 25
Coolant	External coolant
Direction of rotation	r1 ↻ r2 ↻
Max speed [rpm]	6000
Max torque [Nm]	40
Ratio	1:1
H [mm]	112,5
Accessories	
Notes	N.A.
Mounting tips	Not suitable for every application, please check

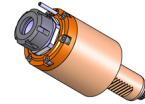

IMPORTANT: CHECK CAREFULLY THE VDI ORIENTATION

Always check live tool dimensions on the turret

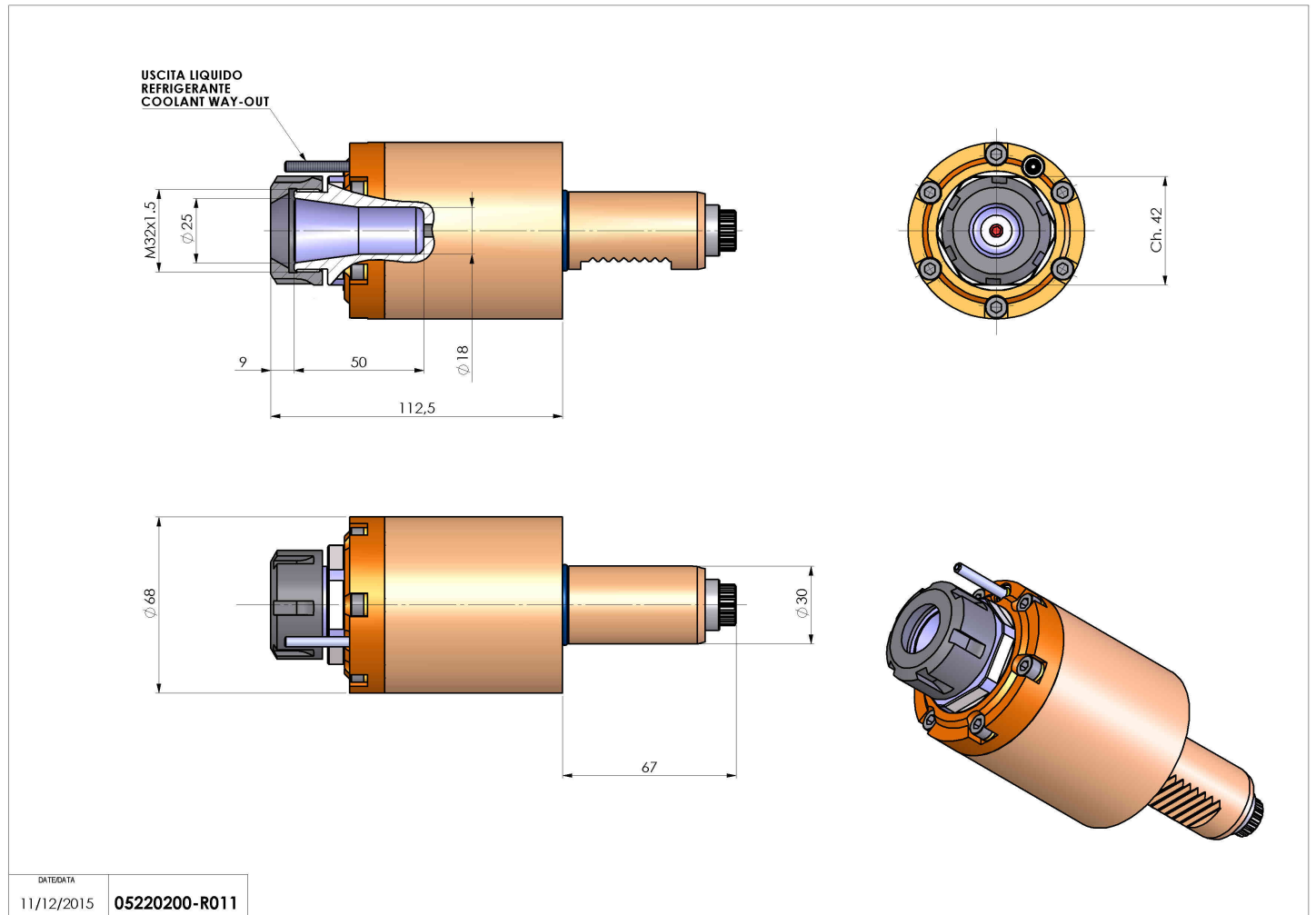

Subject to technical changes

05220300 - LT-S VDI30 ER25RFH112DIN5480SA

Type	LT-S Tool holder straight
Mounting	VDI 30
Tool output	Collet nut ER 25
Coolant	Internal coolant
Direction of rotation	r1 ↻ r2 ↻
Max speed [rpm]	6000
Max torque [Nm]	40
Ratio	1:1
H [mm]	112,5
Accessories	
Notes	N.A.
Mounting tips	Not suitable for every application, please check

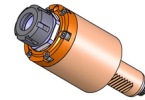

IMPORTANT: CHECK CAREFULLY THE VDI ORIENTATION

Always check live tool dimensions on the turret

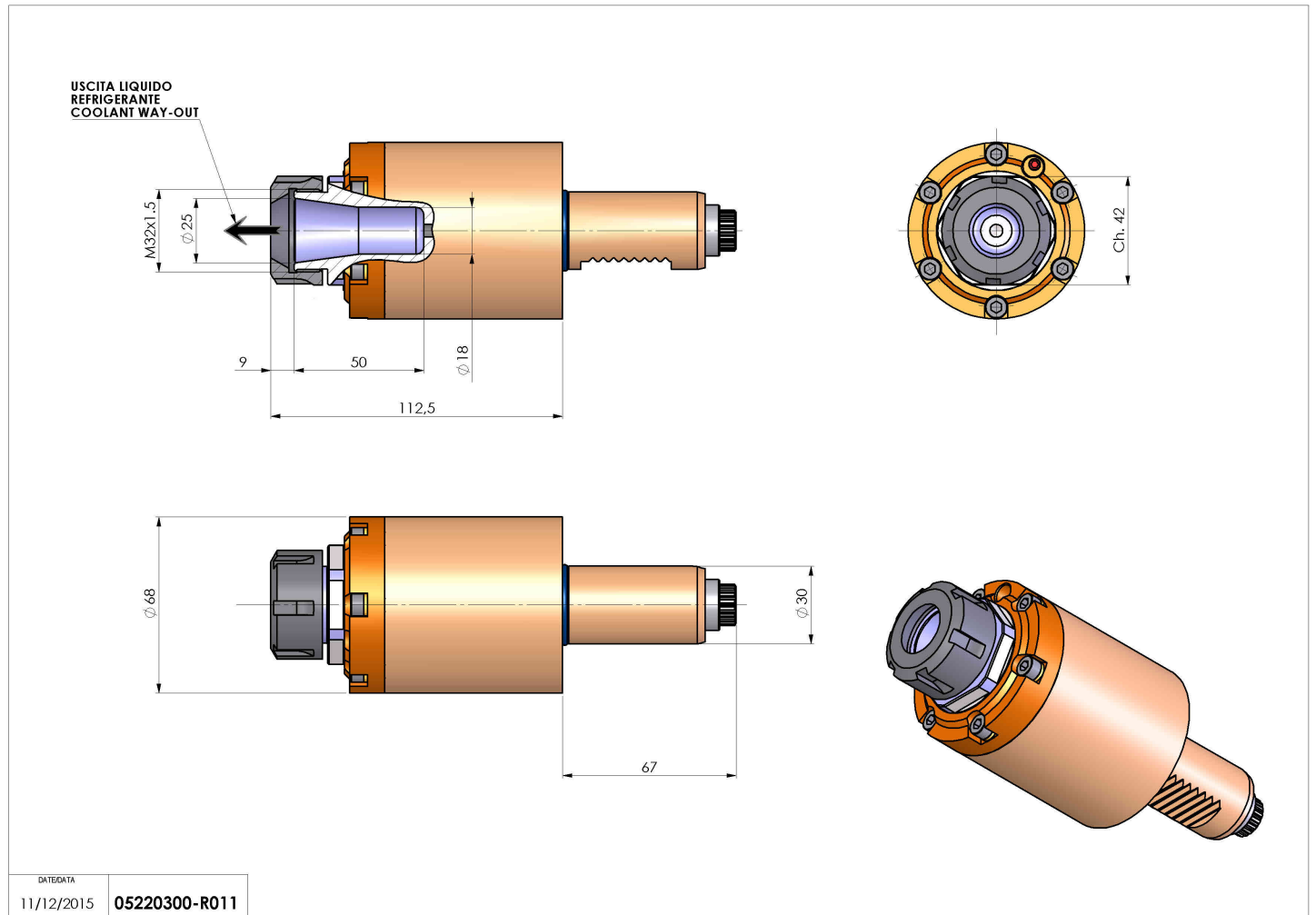

Subject to technical changes

05220500 - LT-A VDI30ER25F H85 DIN5480 SA

Type	LT-A Tool holder angle 90°
Mounting	VDI 30
Tool output	Collet nut ER 25 F - internal nut
Coolant	External coolant
Direction of rotation	r1 ↻ r2 ↻
Max speed [rpm]	6000
Max torque [Nm]	30
Ratio	1:1
H [mm]	85
H1 [mm]	32,5
Accessories	N.A.
Notes	N.A.

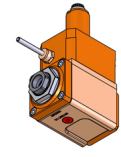

Mounting tips Not suitable for every application, please check

IMPORTANT: CHECK CAREFULLY THE VDI ORIENTATION

Always check live tool dimensions on the turret

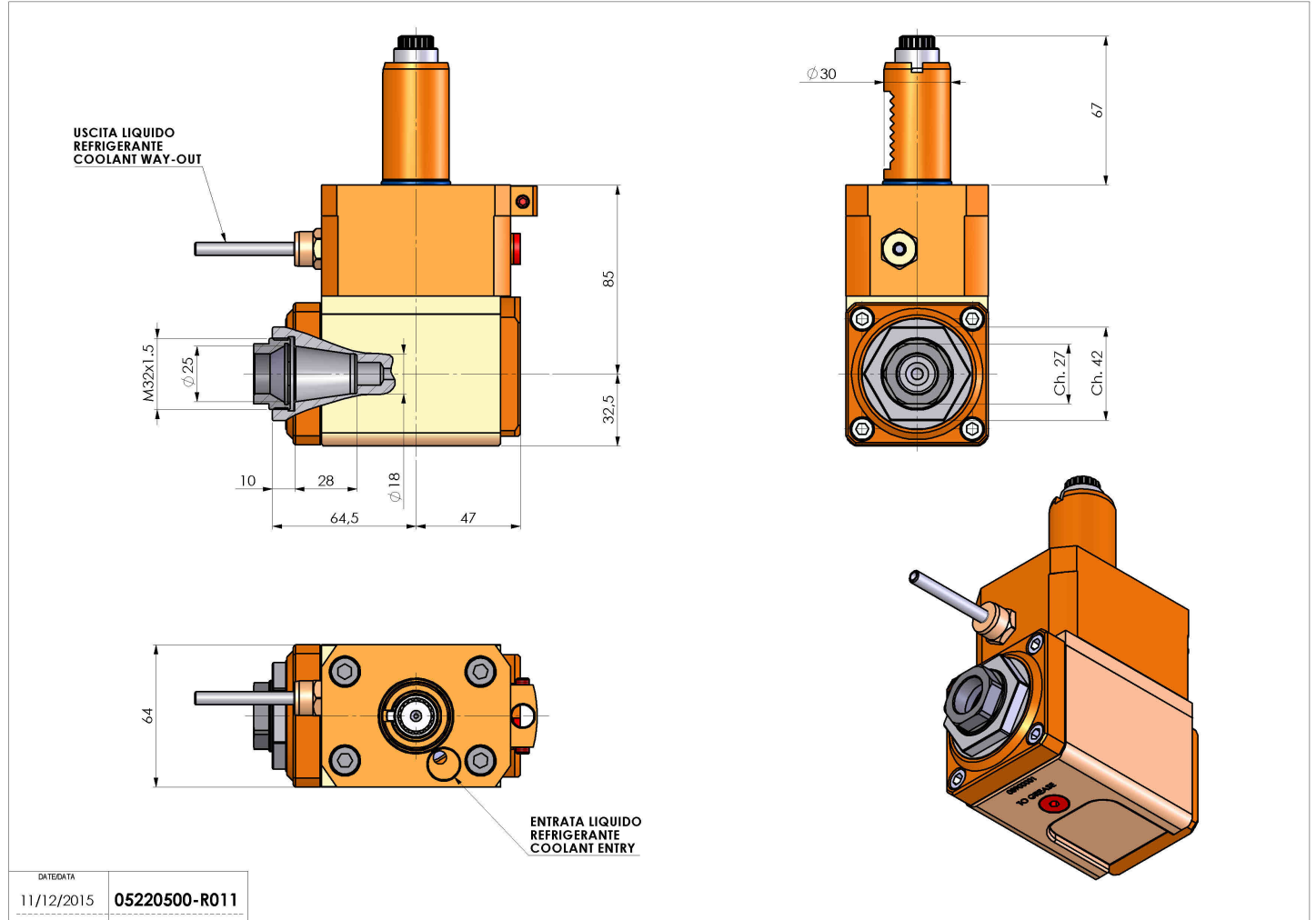

DATE/DATE	11/12/2015	05220500-R011
-----------	------------	---------------

Subject to technical changes

05220600 - LT-A VDI30ER25F H100 DIN5480SA

Type	LT-A Tool holder angle 90°
Mounting	VDI 30
Tool output	Collet nut ER 25 F - internal nut
Coolant	External coolant
Direction of rotation	r1 ↻ r2 ↻
Max speed [rpm]	6000
Max torque [Nm]	30
Ratio	1:1
H [mm]	100
H1 [mm]	32,5
Accessories	N.A.
Notes	N.A.
Mounting tips	Not suitable for every application, please check

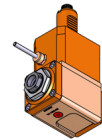

IMPORTANT: CHECK CAREFULLY THE VDI ORIENTATION

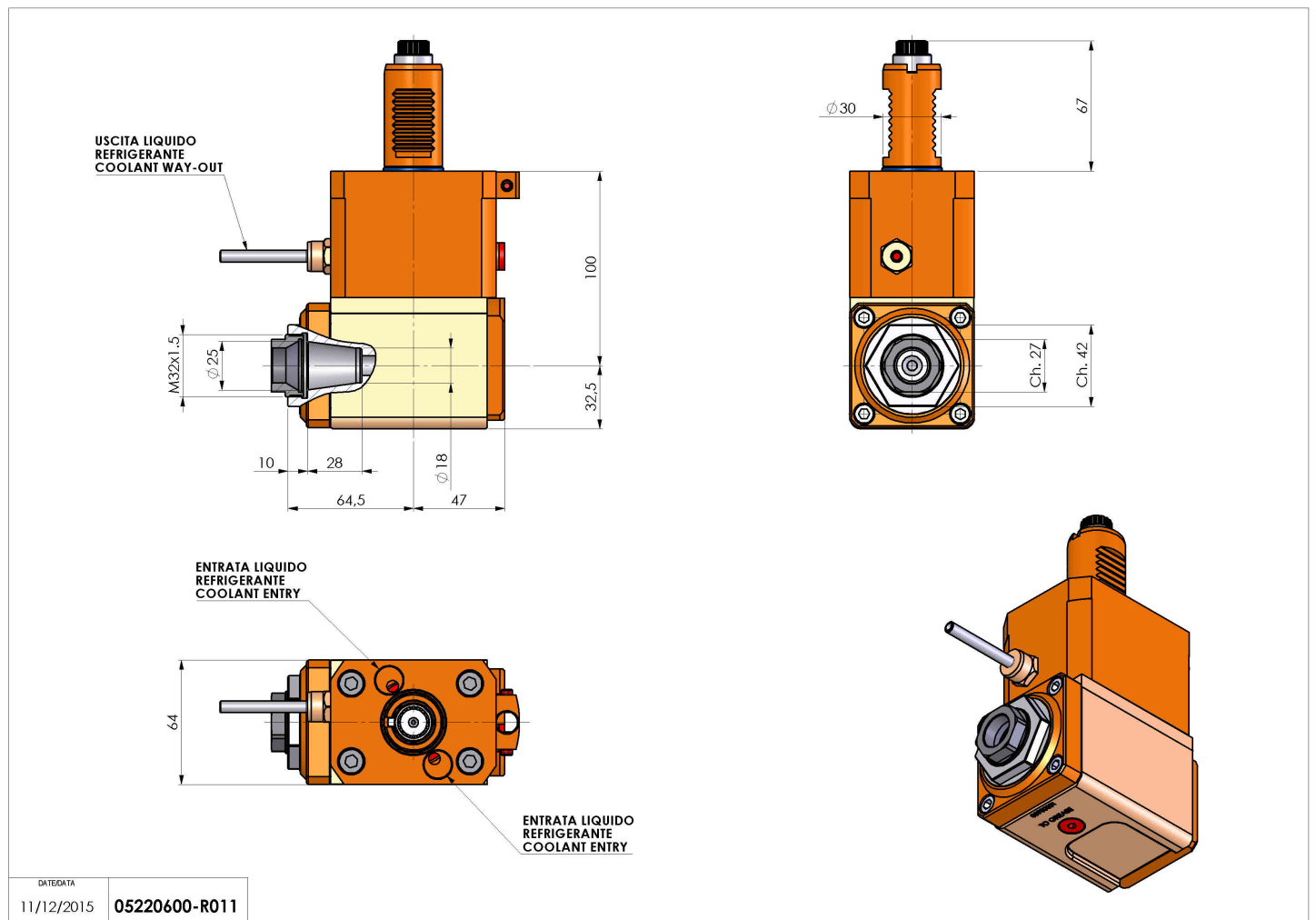

Always check live tool dimensions on the turret



DATE/DATE	11/12/2015
05220600-R011	

Subject to technical changes

05220700 - LT-A VDI30 ER25F RF H85 5480SA

Type	LT-A Tool holder angle 90°
Mounting	VDI 30
Tool output	Collet nut ER 25 F - internal nut
Coolant	Internal coolant
Direction of rotation	r1  r2 
Max speed [rpm]	6000
Max torque [Nm]	30
Ratio	1:1
H [mm]	85
H1 [mm]	32,5
Accessories	N.A.
Notes	N.A.
Mounting tips	Not suitable for every application, please check

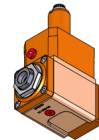

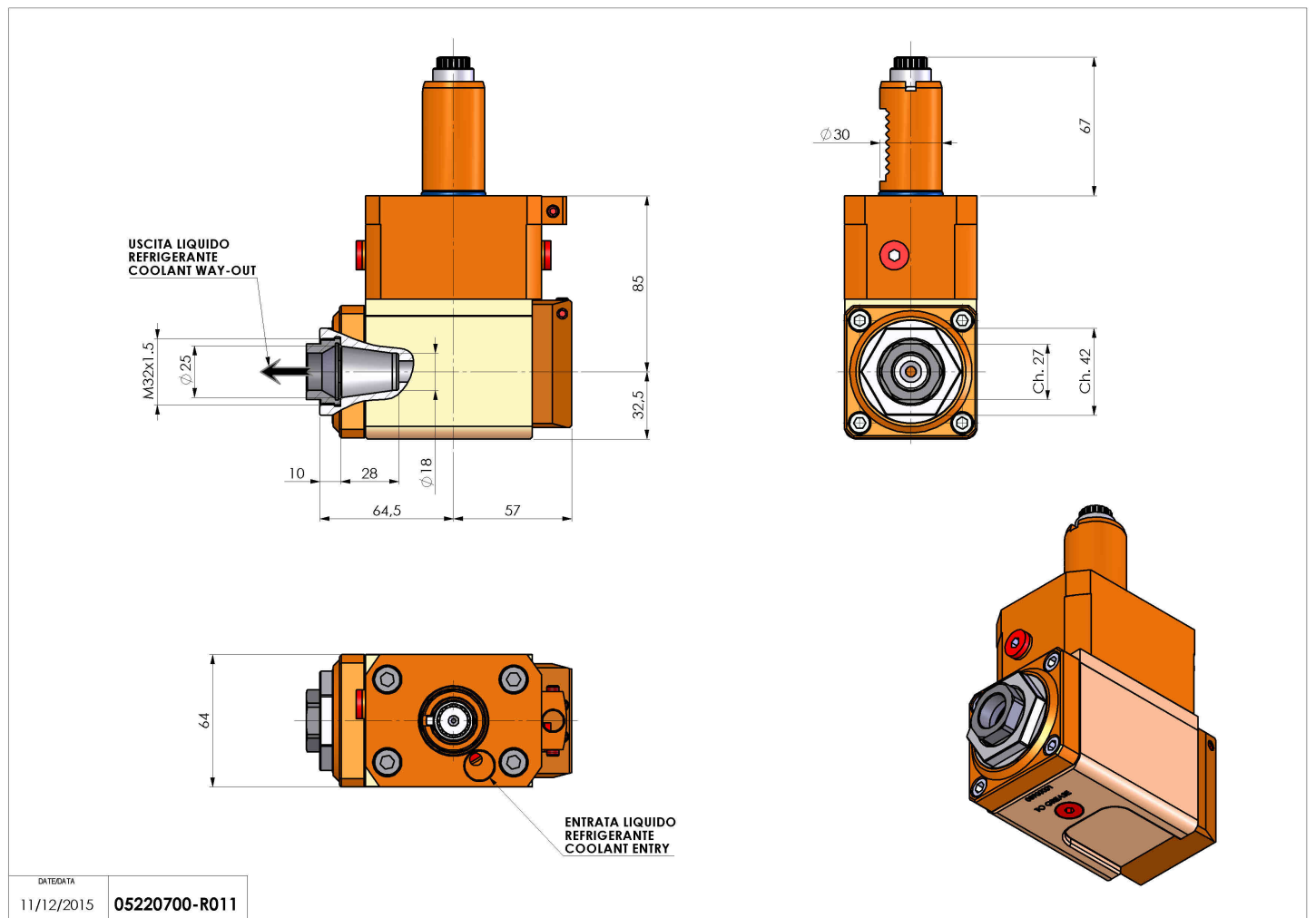

IMPORTANT: CHECK CAREFULLY THE VDI ORIENTATION

Always check live tool dimensions on the turret



Subject to technical changes

05220800 - LT-A VDI30 ER25F RF H1005480SA

Type	LT-A Tool holder angle 90°
Mounting	VDI 30
Tool output	Collet nut ER 25 F - internal nut
Coolant	Internal coolant
Direction of rotation	r1  r2 
Max speed [rpm]	6000
Max torque [Nm]	30
Ratio	1:1
H [mm]	100
H1 [mm]	32,5
Accessories	N.A.
Notes	N.A.
Mounting tips	Not suitable for every application, please check

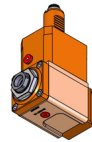

IMPORTANT: CHECK CAREFULLY THE VDI ORIENTATION

Always check live tool dimensions on the turret

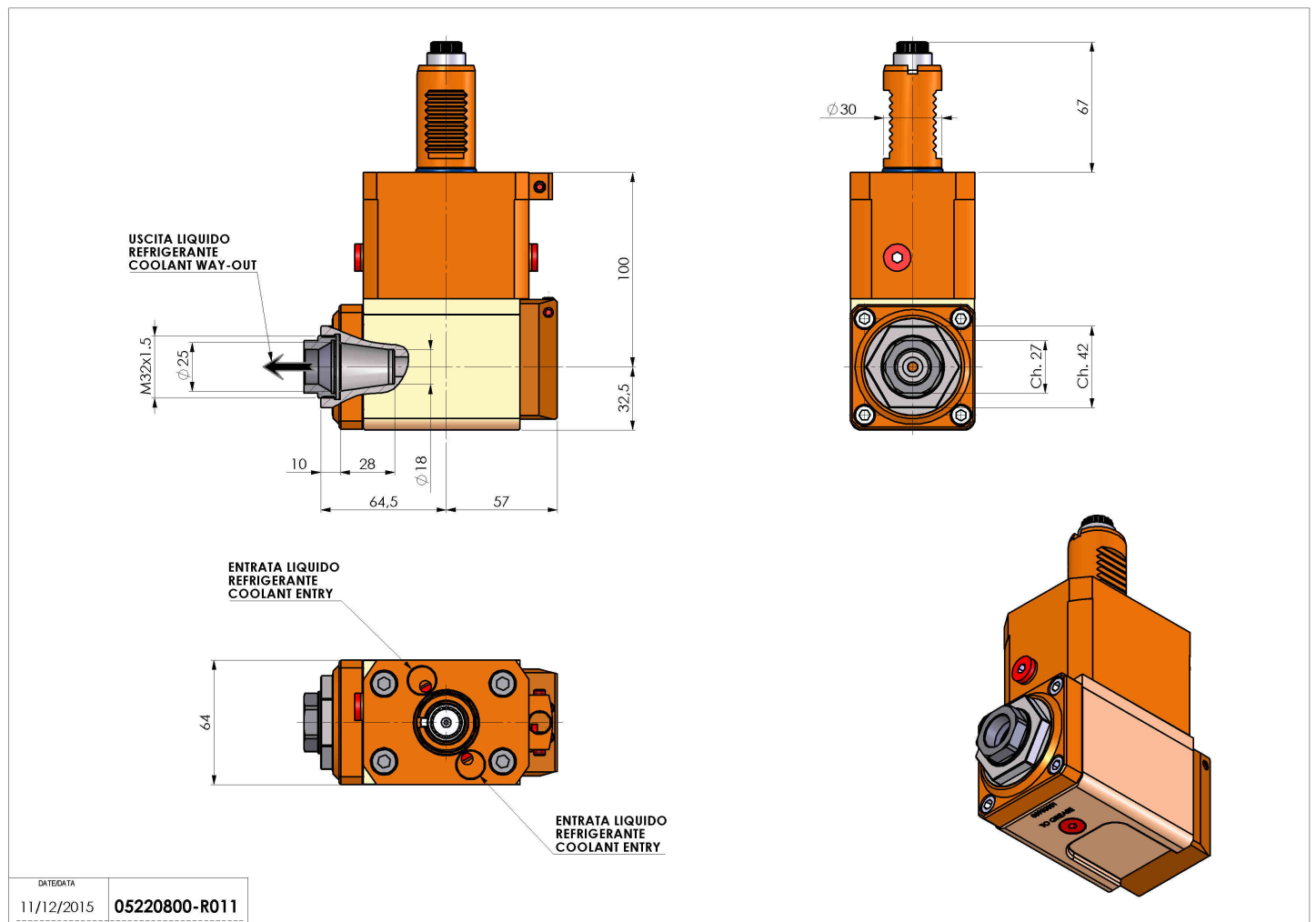

DATE/ATA	11/12/2015	05220800-R011
----------	------------	---------------

Subject to technical changes

05221000 - LT-A VDI30ER25F R-L H85 OFS SA

Type	LT-A OFS Tool holder offset angle 90°
Mounting	VDI 30
Tool output	Collet nut ER 25 F - internal nut
Coolant	External coolant
Direction of rotation	r1 ↻ r2 ↻
Max speed [rpm]	6000
Max torque [Nm]	25
Ratio	1:1
H [mm]	85
H1 [mm]	32,5
Accessories	N.A.
Notes	N.A.
Mounting tips	Not suitable for every application, please check

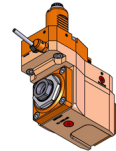

IMPORTANT: CHECK CAREFULLY THE VDI ORIENTATION

Always check live tool dimensions on the turret

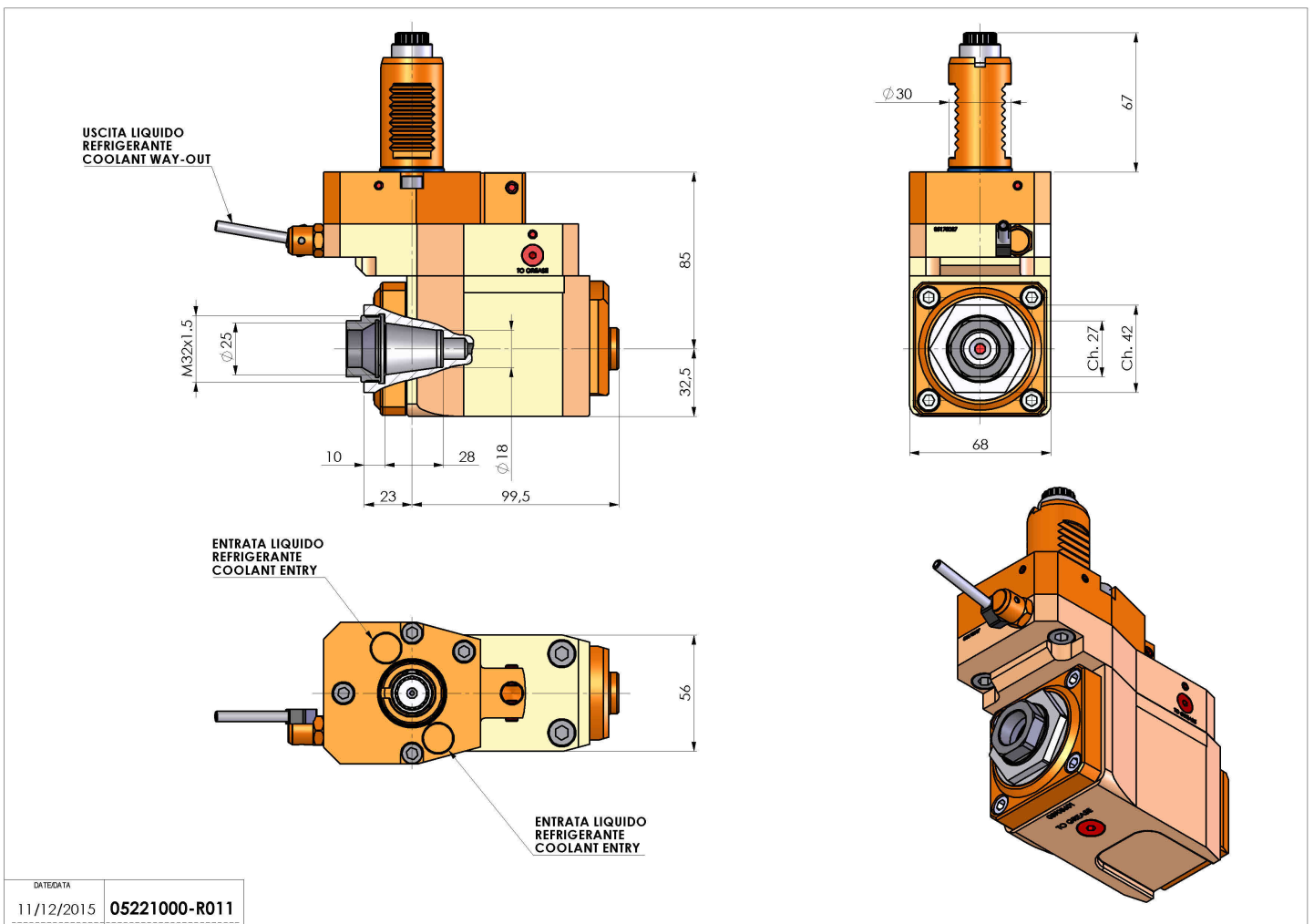

DATE/GATE	11/12/2015	05221000-R011
-----------	------------	---------------

Subject to technical changes

05221900 - LT-T VDI30 ER16F R-L H63-132SA

Type	LT-T Tool holder tiltable
Mounting	VDI 30
Tool output	Collet nut ER 16 F - internal nut
Coolant	External coolant
Direction of rotation	r1 ↻ r2 ↻
Max speed [rpm]	6000
Max torque [Nm]	10
Ratio	1:1
H [mm]	63-132
Accessories	N.A.
Notes	N.A.
Mounting tips	Not suitable for every application, please check

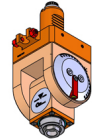

IMPORTANT: CHECK CAREFULLY THE VDI ORIENTATION

Always check live tool dimensions on the turret

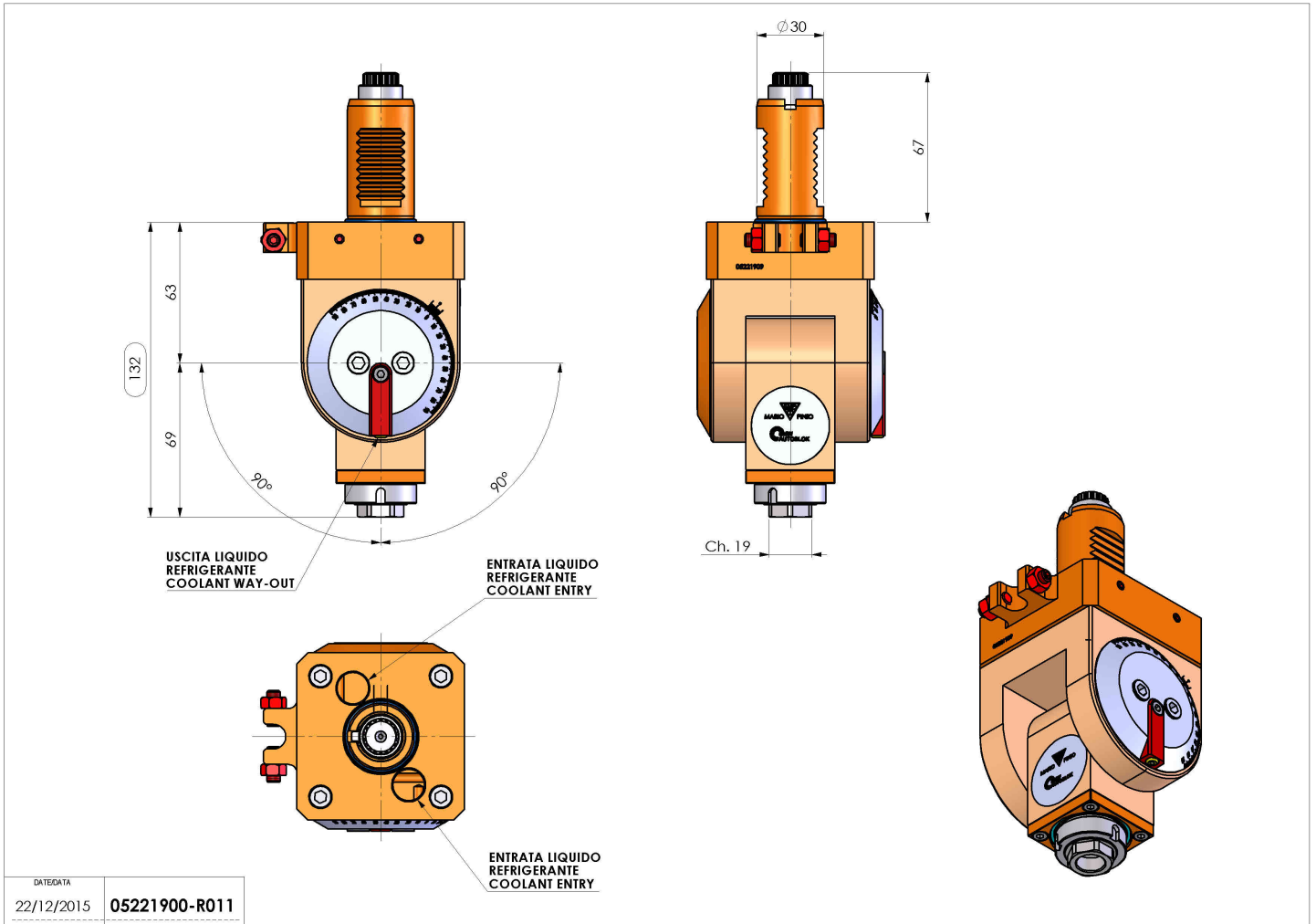

DATE/GATE 22/12/2015 05221900-R011

Subject to technical changes