

DIN 1809
VDI 40

DIPLOMATIC

DN 200 / DN Y200
DN 2 200 / DN 200 2Y50 / DN 200 2Y32

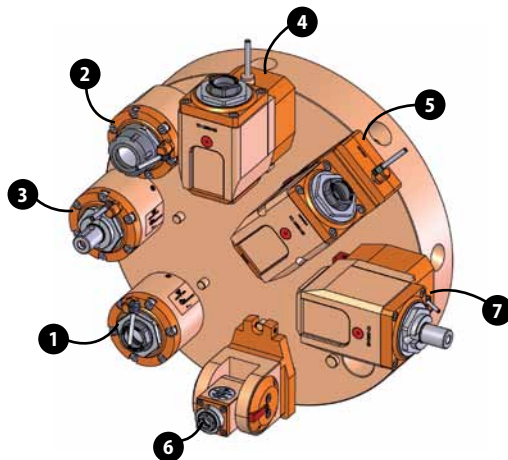
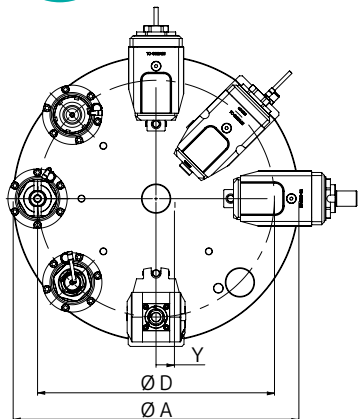

- Right and left turret
Torretta destra e sinistra
Torreta derecha e izquierda
Rechter und linker revolver
Tourelle gauche et droite
Правая и левая револьверная головка
右側及び左側タレット

Y= Shifting from turret axis
Spostamento dall'asse torretta
Desplazamiento desde el eje de la torreta
Verschiebung aus der revolver-achse
Déplacement de l'axe de la tourelle
Смещение от оси револьверной головки
タレット軸から移動

DN 200 / DN Y 200

Ø A	410
Ø D	340
STATION	8-12

Operation	Lavorazione	Operación	Operation	Usinage	Обработка	操作	LT-S ➔ $r_1=r_2$	LT-S ➔ $r_1=r_2$
Collet	Pinza	Pinza	Spannzange	Pince	Цанг	コレット	ER32-F	ER32-F
Speed (rpm)	Velocità (giri / min)	Velocidad (rpm)	Drehzahl (U / Min.)	Vitesse	Скорость (об / мин)	速度	6000	6000
Torque (Nm)	Coppia (Nm)	Par (Nm)	Drehmoment (Nm)	Couple	Крутящий момент (Нм)	トルク	63	63
Ratio	Rapporto	Relación	Übersetzung	Rapport	Передаточное отношение	比率	1:1	1:1
H (mm)	H (mm)	H (mm)	H (mm)	H (mm)	H (mm)	高さ	74	74
H1 (mm)	H1 (mm)	H1 (mm)	H1 (mm)	H1 (mm)	H1 (mm)	高さ1	-	-
Tool length (mm)	Lungh. utensile (mm)	Long. herramienta (mm)	Werkzeuglänge (mm)	Longueur outil (mm)	Длина инструмента (mm)	ツール長さ	-	-
Coolant	Refrigerazione	Refrigerante	Kühlschmiermittel	Réfrigération	Подача сож	クーラント	●●	●
Part No.	Codice	Part. N°	Teile Nummer	Référence	Номер запчасти	部品番号	05192800	05192900

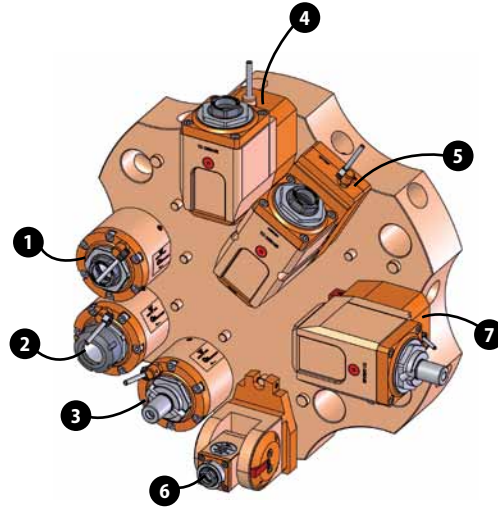
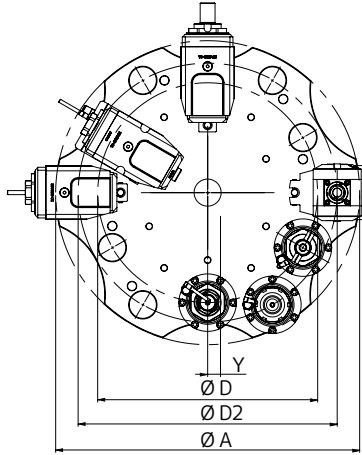

	DN 2 200 DN 200 2Y50	DN 200 2Y32
Ø A	450	470
Ø D	325.7	340
Ø D2	383.5	400
STATION	6+6	6+6

2		3		4		5		6		7	
LT-S → r ₁ =r ₂	LT-S → r ₁ =r ₂	LT-S → r ₁ =r ₂	LT-A ↓ r ₁ =r ₂	LT-A ↓ r ₁ =r ₂	LT-A OFS ↓ r ₁ =r ₂	LT-A OFS ↓ r ₁ =r ₂	LT-T → ↓ r ₁ ≠r ₂	LT-A ↓ r ₁ =r ₂			
ER32	ER32	DIN 138-22	ER32-F	ER32-F	ER32-F	ER32-F	ER16-F	DIN 138-22			
6000	6000	6000	6000	6000	6000	6000	4000	6000			
63	63	63	63	63	50	50	13	63			
1:1	1:1	1:1	1:1	1:1	1:1	1:1	1:1	1:1			
99	99	81	90	90	90	90	132	90			
-	-	-	38	38	38	38	-	38			
-	-	-	-	-	-	-	-	-			
●	○	●	●	○	●	○	●	●			
05193100	05193200	05193000	05193500	05193600	05193700	05193800	05194900	05194300			