

BMT
75

BMT 75

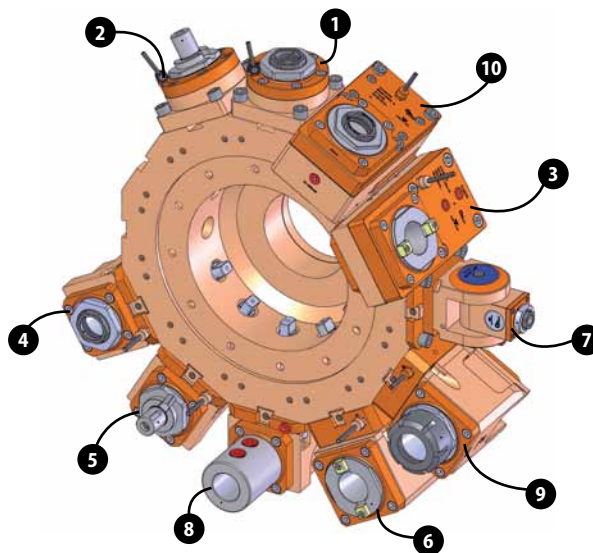
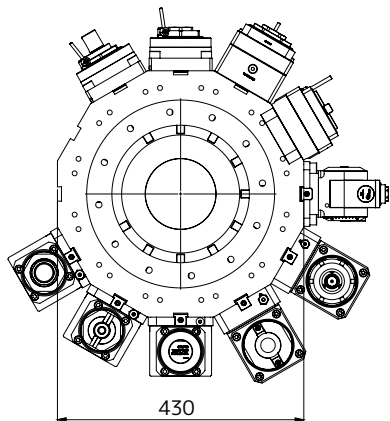

- Main spindle
- Mandrino principale
- Cabezal principal
- Hauptspindel
- Mandrin principale
- Главный шпиндель
- 主軸

Operation	Lavorazione	Operación	Operation	Usinage	Обработка	操作	LT-S $r_1=r_2$	LT-S $r_1=r_2$
Collet	Pinza	Pinza	Spannzange	Pince	Цанг	コレット	ER40-F	ER40-F
Speed (rpm)	Velocità (giri / min)	Velocidad (rpm)	Drehzahl (U / Min.)	Vitesse	Скорость (об / мин)	速度	4000	4000
Torque (Nm)	Coppia (Nm)	Par (Nm)	Drehmoment (Nm)	Couple	Крутящий момент (Нм)	トルク	100	100
Ratio	Rapporto	Relación	Übersetzung	Rapport	Передаточное отношение	比率	1:1	1:1
H (mm)	H (mm)	H (mm)	H (mm)	H (mm)	H (mm)	高さ	70	70
H1 (mm)	H1 (mm)	H1 (mm)	H1 (mm)	H1 (mm)	H1 (mm)	高さ1	-	-
Tool length (mm)	Lungh. utensile (mm)	Long. herramienta (mm)	Werkzeuglänge (mm)	Longueur outil (mm)	Длина инструмента (mm)	ツール長さ	-	-
Coolant	Refrigerazione	Refrigerante	Kühlschmiermittel	Réfrigération	Подача сож	クーラント	●●	●
Part No.	Codice	Part. N°	Teile Nummer	Référence	Номер запчасти	部品番号	05123100	05123200

2	3		4		5	6		7
LT-S $\downarrow r_1=r_2$	LT-S OFS110 $\downarrow r_1=r_2$	LT-S OFS110 $\downarrow r_1=r_2$	LT-A $\rightarrow r_1=r_2$	LT-A $\rightarrow r_1=r_2$	LT-A $\rightarrow r_1=r_2$	LT-A $\rightarrow r_1=r_2$	LT-A $\rightarrow r_1=r_2$	LT-T $\rightarrow \downarrow r_1 \neq r_2$
DIN 138-27	ISO-BT 40	ISO-BT 40	ER40-F	ER40-F	DIN 138-27	ISO-BT 40	ISO-BT 40	ER20-F
4000	4000	4000	4000	4000	4000	4000	4000	3000
100	180	180	80	80	80	180	180	20
1:1	1:1	1:1	1:1	1:1	1:1	1:1	1:1	1:1
75.5	80	80	60	60	60	90	90	151
-	-	-	43	43	43	52	52	-
-	-	-	-	-	-	-	-	-
05123600	05123800	05123700	05123300	05123400	05123500	05123900	05124000	05124500

8	new	new	new	9 new	new	10 new
LT-A $\rightarrow r_1=r_2$	LT-A $\rightarrow r_1=r_2$	LT-A $\rightarrow r_1=r_2$	LT-A $\rightarrow r_1=r_2$	LT-A $\rightarrow r_1=r_2$	LT-S OFS95 $\downarrow r_1=r_2$	LT-S OFS95 $\downarrow r_1=r_2$
WLD-40	ER-50	ER-50	ER-50	ER-50	ER-40	ER-40
4000	4000	4000	in 4000 / out 2000	in 4000 / out 2000	in 4000 / out 2000	in 4000 / out 2000
80	180	180	in 60 / out 120	in 60 / out 120	in 120 / out 240	in 120 / out 240
1:1	1:1	1:1	2:1	2:1	2:1	2:1
60	90	90	90	90	108	108
43	52	52	52	52	-	-
-	-	-	-	-	-	-
05124300	05304700	05304800	05304900	05305000	05129000	05129100