

REVOLVING CENTER CNC HEAVY DUTY - R MODEL STUB POINT

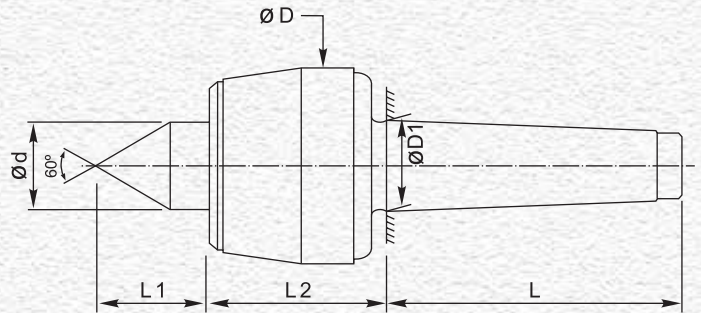

Part No.	Shank Taper	Point Style	ϕd mm	ϕD mm	$\phi D1$ mm	L1 mm	L2 mm	L mm	Max. Job Wt. Kg.	Conc. Error mm	Max. RPM
HSC MT2 CNC HDRS	MT-2	Stub Point	20	46	17.780	25.0	48.5	64.0	200	0.005	7000
HSC MT3 CNC HDRS	MT-3	Stub Point	28	62	23.825	34.0	62.5	81.0	500	0.005	5000
HSC MT4 CNC HDRS	MT-4	Stub Point	32	68	31.267	41.0	65.0	102.5	800	0.005	3800
HSC MT5 CNC HDRS	MT-5	Stub Point	38	87	44.399	51.0	80.5	129.5	2000	0.005	3000
HSC MT6 CNC HDRS	MT-6	Stub Point	55	112	63.348	63.0	106.0	182	3500	0.010	2600