

CNC DEAD CENTER PLAIN EXTENDED

With Draw Off Nut

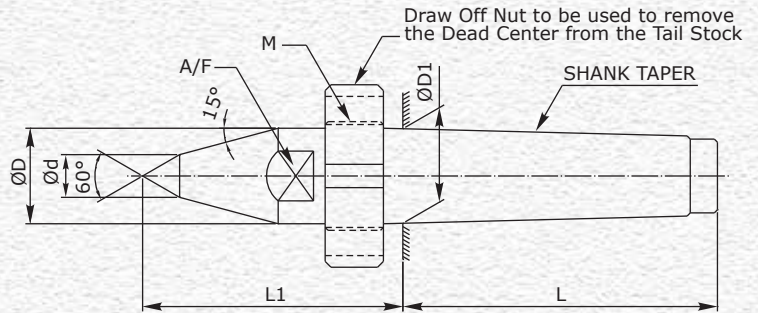

Part No.	Shank Taper	L mm	L1 mm	$\varnothing D$ mm	$\varnothing D1$ mm	$\varnothing d$ mm	M (THREAD)	A/F mm
CNC DC MT2 PE	MT-2	64.0	52.0	18.0	17.780	8	M22 X 1.5	15
CNC DC MT3 PE	MT-3	81.0	67.0	24.1	23.825	11	M27 X 1.5	21
CNC DC MT4 PE	MT-4	102.5	83.5	31.6	31.267	14	M36 X 1.5	28
CNC DC MT5 PE	MT-5	129.5	107.0	44.7	44.399	18	M48 X 1.5	40
CNC DC MT6 PE	MT-6	182.0	145.0	63.8	63.348	20	M68 X 1.5	55