

# CNC DEAD CENTER PLAIN STUB With Draw Off Nut

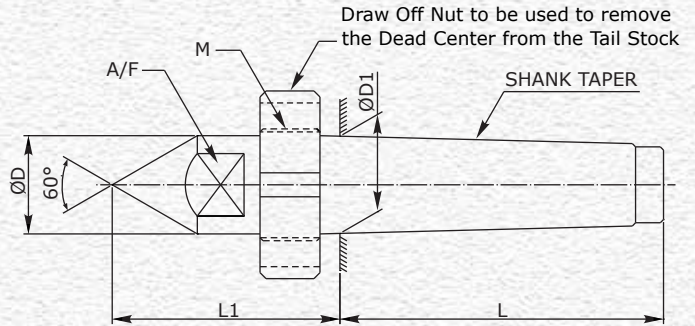

Part No.	Shank Taper	L mm	L1 mm	ØD mm	ØD1 mm	M (THREAD)	A/F mm
CNC DC MT2 PS	MT-2	64.0	48.0	18.0	17.780	M22 X 1.5	14
CNC DC MT3 PS	MT-3	81.0	57.0	24.1	23.825	M27 X 1.5	19
CNC DC MT4 PS	MT-4	102.5	72.5	31.6	31.267	M36 X 1.5	27
CNC DC MT5 PS	MT-5	129.5	87.5	44.7	44.399	M48 X 1.5	36
CNC DC MT6 PS	MT-6	182.0	108.0	63.8	63.348	M68 X 1.5	55