

# CNC PIPE CENTER - BLUNT

## 60° Angle Revolving Cone (Not Dead)

With Draw off Nut

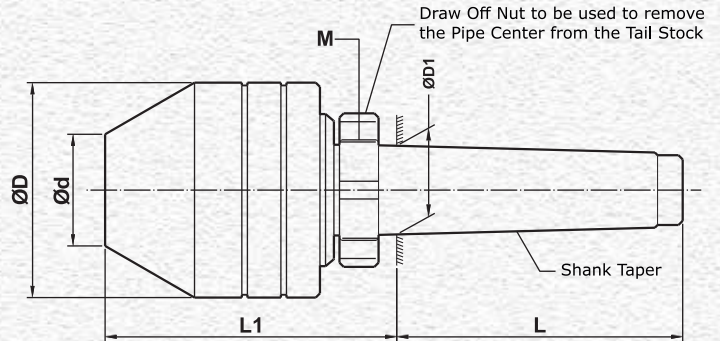

Part No.	Shank Taper	Ød mm	ØD mm	ØD1 mm	L mm	L1 mm	Max. Job Wt. Kg.	Conc. Error mm	Max. RPM
CPC MT3 40-75	MT-3	40	75	23.825	81.0	99.5	150	0.012	3500
CPC MT4 40-75	MT-4	40	75	31.267	102.5	103.0	200	0.012	3500
CPC MT5 40-75	MT-5	40	75	44.399	129.5	103.0	300	0.012	3500
CPC MT3 50-100	MT-3	50	100	23.825	81.0	106.0	200	0.012	2250
CPC MT4 50-100	MT-4	50	100	31.267	102.5	111.5	300	0.012	2250
CPC MT5 50-100	MT-5	50	100	44.399	129.5	109.5	400	0.012	2250
CPC MT4 65-125	MT-4	65	125	31.267	102.5	118.5	400	0.015	1750
CPC MT5 65-125	MT-5	65	125	44.399	129.5	119.5	500	0.015	1750
CPC MT6 65-125	MT-6	65	125	63.348	182	123.0	800	0.015	1750
CPC MT4 75-160	MT-4	75	160	31.267	102.5	134.5	500	0.015	1250
CPC MT5 75-160	MT-5	75	160	44.399	129.5	135.5	700	0.015	1250
CPC MT6 75-160	MT-6	75	160	63.348	182	139.0	1000	0.015	1250