

# REVOLVING CENTER CNC HEAVY DUTY - R MODEL PROFILED POINT

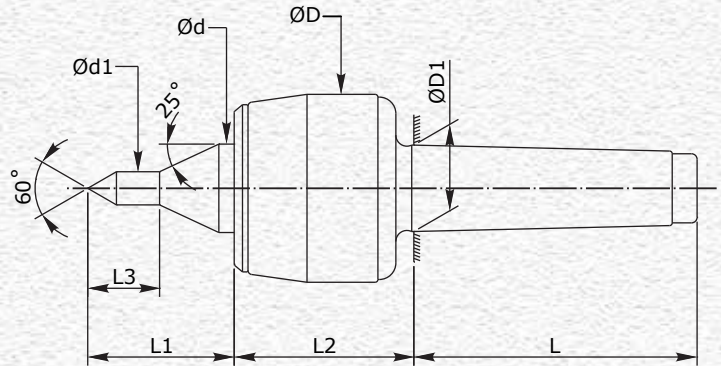

Part No.	Shank Taper	Point Style	Ød mm	Ød1 mm	ØD mm	ØD1 mm	L1 mm	L2 mm	L3 mm	L mm	Max. Job Wt. Kg.	Conc. Error mm	Max. RPM
HSC MT2 CNC HDRP	MT-2	Profiled Point	20	8	46	17.780	35.0	48.5	16	64.0	100	0.005	7000
HSC MT3 CNC HDRP	MT-3	Profiled Point	28	10	62	23.825	47.0	62.5	20	81.0	150	0.005	5000
HSC MT4 CNC HDRP	MT-4	Profiled Point	32	12	68	31.267	53.0	65.0	26	102.5	180	0.005	3800
HSC MT5 CNC HDRP	MT-5	Profiled Point	38	14	87	44.399	65.0	80.5	30	129.5	280	0.005	3000