



Radius Milling
R角加工



Copy Milling
曲面加工



Face Milling
平面加工

IRD

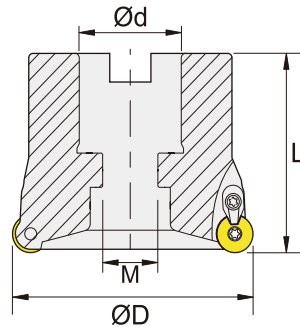

Item Code	Dimensions, mm				Teeth	Insert	Screw	Clamp	Clamp Screw	Wrench
	D	d	L	M						
IRD103-D504-22.0	50	22.0	40	11	4	RD..1003..	MS3509A	MC35-143	MS3509A	TF15
IRD103-D505-22.0	50	22.0	40	11	5					
IRD103-D504-25.4	50	25.4	40	11	4					
IRD103-D505-25.4	50	25.4	40	11	5					
IRD103-D635-25.4	63	25.4	50	13	5					
IRD103-D636-25.4	63	25.4	50	13	6					

RDMX		P Alloy Steels 鋼 M Stainless Steels 不鏽鋼 K Cast Irons 鑄鐵 H Hard Steel 高硬鋼		F Finishing 精加工 S Semi Finishing 輕加工 M Medium 中加工 R Roughing 粗加工									
Type 刀片形狀	Designation 型號	Dimension (mm) 尺寸			Grade 材質	Application 用途				工件材質			
		lc	S	d1		F	S	M	R	P	M	K	H
	RDMX 1003MOE	10.00	3.18	4.15	CP3020		★	★★★★	★	◎	○	○	○
					CP3050		★	★★★★	★	◎	○	○	○
					CP6060		★	★★★★	★	○	○	◎	◎

★ Acceptable 可接受 ★★ Recommended 推薦 ★★★ Excellent 強力推薦 ◎ First Recommend 第一推薦 ○ Second Recommend 次要推薦