

- EN** Side and face milling cutters
- DE** Scheibenfräser
- RU** Фрезы дисковые трехсторонние | среднезубые

DIN 138

DIN 885A

typ N

$\lambda=10^\circ$
 $\gamma=12^\circ$

typ H

$\lambda=10^\circ$
 $\gamma=8^\circ$

HSS Co5

7202
7302

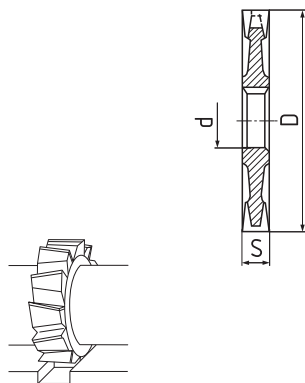

typ N

$\lambda=10^\circ$
 $\gamma=12^\circ$

typ H

$\lambda=10^\circ$
 $\gamma=8^\circ$

D	S	d	Z	Z
js 16	k 11	H 7	7202	7302
50	3	16	12	16
50	4	16	12	16
50	5	16	12	16
50	6	16	12	16
50	8	16	12	16
50	10	16	12	16
63	3	22	12	18
63	4	22	12	18
63	5	22	12	18
63	6	22	12	18
63	8	22	12	18
63	10	22	12	18
63	12	22	12	18
63	14	22	12	18
63	16	22	12	18
63	18	22	12	18
80	3	27	14	
80	4	27	14	20
80	5	27	14	20
80	6	27	14	20
80	8	27	14	20
80	10	27	14	18
80	12	27	14	18
80	14	27	14	18
80	16	27	14	18
80	18	27	14	18
80	20	27	14	18
100	3	32	14	20
100	4	32	14	20
100	5	32	14	20
100	6	32	14	20

720275	730275
.05003	.05003
.05004	.05004
.05005	.05005
.05006	.05006
.05008	.05008
.05010	.05010
.06303	.06303
.06304	.06304
.06305	.06305
.06306	.06306
.06308	.06308
.06310	.06310
.06312	.06312
.06314	.06314
.06316	.06316
.06318	
.08003	
.08004	.08004
.08005	.08005
.08006	.08006
.08008	.08008
.08010	.08010
.08012	.08012
.08014	.08014
.08016	.08016
.08018	.08018
.08020	.08020
.10003	.10003
.10004	.10004
.10005	.10005
.10006	.10006



- EN Side and face milling cutters
- DE Scheibenfräser
- RU Фрезы дисковые трехсторонние | среднезубые

DIN 138

DIN 885A

typ N

λ=10°
γ=12°

typ H

λ=10°
γ=8°

7202

7302

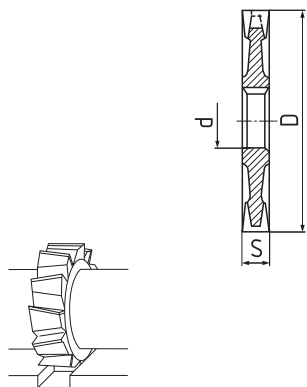

typ N

λ=10°
γ=12°

typ H

λ=10°
γ=8°

D	S	d	Z	Z
js 16	k 11	H 7	7202	7302
100	8	32	14	20
100	10	32	14	20
100	12	32	14	20
100	14	32	14	20
100	16	32	14	20
100	18	32	14	20
100	20	32	14	20
100	22	32	14	20
100	25	32	14	20
125	4	32	16	
125	5	32	16	24
125	6	32	16	24
125	8	32	16	24
125	10	32	16	22
125	12	32	16	22
125	14	32	16	22
125	16	32	16	22
125	18	32	16	22
125	20	32	16	22
125	22	32	16	
125	25	32	16	22
125	28	32	16	22

720275	730275
.10008	.10008
.10010	.10010
.10012	.10012
.10014	.10014
.10016	.10016
.10018	.10018
.10020	.10020
.10022	
.10025	.10025
.12504	
.12505	.12505
.12506	.12506
.12508	.12508
.12510	.12510
.12512	.12512
.12514	.12514
.12516	.12516
.12518	.12518
.12520	.12520
.12522	
.12525	.12525
.12528	.12528

Řezné podmínky / Cutting conditions / Schnittbedingungen / Условия резания

Material	Ap	Ae	Vc	fz (mm/z)					
				Ø 50	Ø 80	Ø 100	Ø 160	Ø 200	
720275									
P.1	≤ 600 N/mm ²	0,1xD	1xb	37,5	0,050	0,070	0,080	0,090	0,090
P.2	≤ 850 N/mm ²	0,1xD	1xb	32,5	0,050	0,070	0,080	0,090	0,090
K.1	< 240 HB	0,1xD	1xb	30	0,050	0,070	0,080	0,090	0,090
N.2	Si ≤ 12%	0,1xD	1xb	160-260	0,065	0,091	0,104	0,117	0,117
N.4	≤ 800 N/mm ²	0,1xD	1xb	60-100	0,050	0,070	0,080	0,090	0,090

- EN** Side and face milling cutters
- DE** Scheibenfräser
- RU** Фрезы дисковые трехсторонние | среднезубые

DIN 138
DIN 885A
typ N
 $\lambda=10^\circ$
 $\gamma=12^\circ$
typ H
 $\lambda=10^\circ$
 $\gamma=8^\circ$

HSS Co5

7202

7302

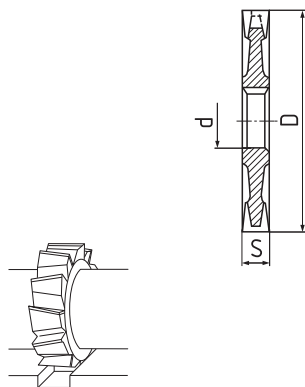

typ N $\lambda=10^\circ$
 $\gamma=12^\circ$

typ H $\lambda=10^\circ$
 $\gamma=8^\circ$

D	S	d	Z	Z
js 16	k 11	H 7	7202	7302
160	6	40	18	26
160	8	40	18	26
160	10	40	18	26
160	12	40	18	26
160	14	40	18	26
160	16	40	18	26
160	18	40	18	26
160	20	40	18	26
160	25	40	18	26
160	32	40	18	26
200	8	40	24	32
200	10	40	24	32
200	12	40	24	32
200	14	40	24	32
200	16	40	24	32
200	18	40	24	32
200	20	40	24	32
200	25	40	24	32
200	32	40	24	32
250*	8	40		38
250*	10	40		38
250*	12	40		38

720275	730275
.16006	.16006
.16008	.16008
.16010	.16010
.16012	.16012
.16014	.16014
.16016	.16016
.16018	.16018
.16020	.16020
.16025	.16025
.16032	.16032
.20008	.20008
.20010	.20010
.20012	.20012
.20014	.20014
.20016	.20016
.20018	.20018
.20020	.20020
.20025	.20025
.20032	.20032
	.25008
	.25010
	.25012

*) = HSS

Řezné podmínky / Cutting conditions / Schnittbedingungen / Условия резания

Material	Ap	Ae	Vc	fz (mm/z)						
				Ø 50	Ø 80	Ø 100	Ø 160	Ø 200		
730275										
P.1	≤ 600 N/mm ²	0,1xD	1xb	37,5	0,050	0,070	0,080	0,090	0,090	
P.2	≤ 850 N/mm ²	0,1xD	1xb	32,5	0,050	0,070	0,080	0,090	0,090	
P.4	≤ 900 N/mm ²	0,1xD	1xb	25	0,050	0,070	0,080	0,090	0,090	
P.5	≤ 1100 N/mm ²	0,1xD	1xb	18	0,050	0,070	0,080	0,090	0,090	
K.1	< 240 HB	0,1xD	1xb	30	0,050	0,070	0,080	0,090	0,090	
K.2	> 240 HB	0,1xD	1xb	22	0,050	0,070	0,080	0,090	0,090	
M.2	750 - 850 N/mm ²	0,1xD	1xb	10	0,050	0,070	0,080	0,090	0,090	
N.4	≤ 800 N/mm ²	0,1xD	1xb	60-100	0,050	0,070	0,080	0,090	0,090	

- EN Side and face milling cutters | fine teeth
- DE Scheibenfräser | feingezahnt
- RU Фрезы дисковые трехсторонние | мелкозубые

DIN 138

DIN 885A

typ H

λ=10°
γ=10°

HSS
Co8

7302

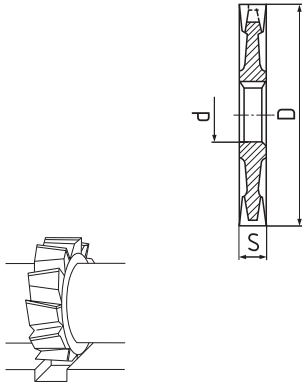

D js 16	S k 11	d H 7	Z
50	4	16	14
50	5	16	14
50	6	16	14
50	8	16	14
50	10	16	14
63	4	22	16
63	5	22	16
63	6	22	16
63	7	22	16
63	8	22	16
63	9	22	16
63	10	22	16
63	12	22	16
63	14	22	16
63	16	22	16
80	4	27	18
80	5	27	18
80	6	27	18
80	7	27	18
80	8	27	18
80	9	27	18
80	10	27	18
80	12	27	18
80	14	27	18
80	16	27	18
80	18	27	16
80	20	27	16
100	4	32	20
100	5	32	20
100	6	32	20
100	7	32	20
100	8	32	20
100	9	32	20

730278
.05004
.05005
.05006
.05008
.05010
.06304
.06305
.06306
.06307
.06308
.06309
.06310
.06312
.06314
.06316
.08004
.08005
.08006
.08007
.08008
.08009
.08010
.08012
.08014
.08016
.08018
.08020
.10004
.10005
.10006
.10007
.10008
.10009

- EN Side and face milling cutters | fine teeth
 DE Scheibenfräser | feingezahnt
 RU Фрезы дисковые трехсторонние | мелкозубые

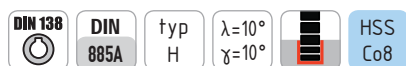

7302

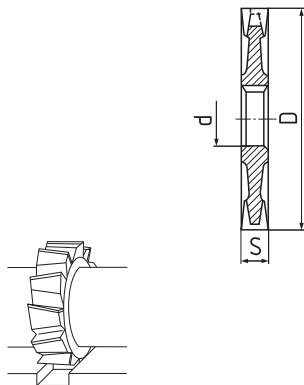

D js 16	S k 11	d H 7	Z
100	10	32	20
100	12	32	20
100	14	32	20
100	16	32	20
100	18	32	20
100	20	32	20
100	22	32	18
100	25	32	18
125	5	32	22
125	6	32	22
125	8	32	22
125	10	32	22
125	12	32	22
125	14	32	22
125	16	32	22
125	18	32	22
125	20	32	22
125	22	32	20
125	25	32	20

730278

.10010
 .10012
 .10014
 .10016
 .10018
 .10020
 .10022
 .10025
 .12505
 .12506
 .12508
 .12510
 .12512
 .12514
 .12516
 .12518
 .12520
 .12522
 .12525

Řezné podmínky / Cutting conditions / Schnittbedingungen / Условия резания

Material	A _p	A _e	V _c	f _z (mm/z)				
				Ø 50	Ø 80	Ø 100	Ø 160	
P.1	≤ 600 N/mm ²	0,1xD	1xb	45	0,050	0,070	0,080	0,090
P.2	≤ 850 N/mm ²	0,1xD	1xb	39	0,050	0,070	0,080	0,090
P.3	≤ 1100 N/mm ²	0,1xD	1xb	24	0,050	0,070	0,080	0,090
P.4	≤ 900 N/mm ²	0,1xD	1xb	30	0,050	0,070	0,080	0,090
P.5	≤ 1100 N/mm ²	0,1xD	1xb	24	0,050	0,070	0,080	0,090
P.6	> 1100 N/mm ²	0,1xD	1xb	20	0,035	0,049	0,056	0,063
M.2	750 - 850 N/mm ²	0,1xD	1xb	15	0,050	0,070	0,080	0,090
K.1	< 240 HB	0,1xD	1xb	35	0,050	0,070	0,080	0,090
K.2	> 240 HB	0,1xD	1xb	25	0,050	0,070	0,080	0,090
N.4	≤ 800 N/mm ²	0,1xD	1xb	80-120	0,050	0,070	0,080	0,090
S.1	≤ 1500 N/mm ²	0,1xD	1xb	12	0,035	0,049	0,056	0,063
S.2	≤ 1250 N/mm ²	0,1xD	1xb	12	0,035	0,049	0,056	0,063