

- EN** Side and face milling cutters
- DE** Scheibenfräser
- RU** Фрезы дисковые трехсторонние | среднезубые

DIN 138 typ N typ H $\lambda=10^\circ$ $\gamma=10^\circ$ **HSSE** = litá HSS • cast HSS
HHS fondu • литая HSS

7203

7303

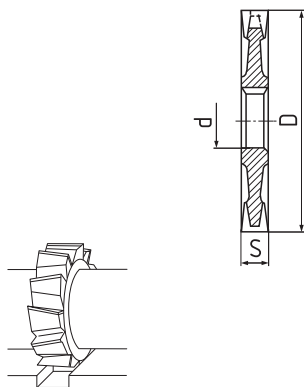

ČSN 222161 typ N

ČSN 222165 typ H

D js 16	S s 10	d 7203	d 7303	Z 7203	Z 7303
50	4		16		18
50	5		16		18
50	6		16		18
63	4		22		20
63	5		22		20
63	6		22		20
63	8	22	22	12	20
63	10	22	22	12	20
63	12	22	22	12	20
80	6		22		22
80	8	27	22	14	22
80	10	27	22	14	22
80	10	22		14	
80	12	27	22	14	22
100	8		22		24
100	10	27	22	14	24
100	12	27		14	
100	12	22		14	
100	14	27		14	
100	14	32	22	14	24
100	14	27		14	
100	16	32	27	14	24

720373	730373
	.05004
	.05005
	.05006
	.06304
	.06305
	.06306
.06308	.06308
.06310	.06310
.06312	.06312
	.08006
.08008	.08008
.08010	.08010
.0801022	
.08012	.08012
	.10008
.1001027	.10010
.10012	
.1001222	
.1001227	
.10014	.10014
.1001427	
.10016	.10016

Řezné podmínky / Cutting conditions / Schnittbedingungen / Условия резания

Material	A _p	A _e	V _c	f _z (mm/z)			
				Ø 50	Ø 80	Ø 100	Ø 160
720373							
P.1 ≤ 600 N/mm ²	0,1xD	1xb	30	0,050	0,070	0,080	0,090
P.2 ≤ 850 N/mm ²	0,1xD	1xb	26	0,050	0,070	0,080	0,090
K.1 < 240 HB	0,1xD	1xb	25	0,050	0,070	0,080	0,090
N.4 ≤ 800 N/mm ²	0,1xD	1xb	50-90	0,050	0,070	0,080	0,090
N.2 Si ≤ 12%	0,1xD	1xb	140-240	0,065	0,091	0,104	0,117
730373							
P.2 ≤ 850 N/mm ²	0,1xD	1xb	26	0,050	0,070	0,080	0,090
P.4 ≤ 900 N/mm ²	0,1xD	1xb	20	0,050	0,070	0,080	0,090
K.2 > 240 HB	0,1xD	1xb	17	0,050	0,070	0,080	0,090

- EN Side and face milling cutters | fine teeth
- DE Scheibenfräser | feingezahnt
- RU Фрезы дисковые трехсторонние | мелкозубые

= litá HSS • cast HSS
 HHS fondu • литая HSS

7203

7303

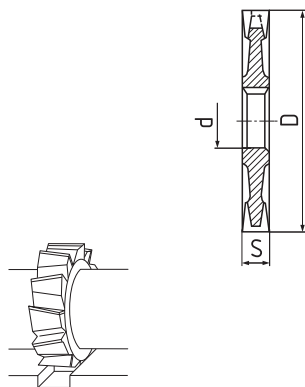

ČSN 222161 typ N

ČSN 222165 typ H

D	S	d	d	Z	Z
js 16	s 10	7203	7303	7203	7303
125	8		32		28
125	12	32	27	16	26
125	14	32		16	
125	14	27		16	
125	14	40		16	
125	16	32	27	16	26
125	16	40		16	
125	18	40	32	16	26
125	20		32		26
160	14	40		18	
160	16	40		18	
160	16	32		18	
160	18	40	32	18	28
160	20	40		18	
160	22		40		28

720373	730373
	.12508
.12512	.12512
.12514	
.1251427	
.1251440	
.12516	.12516
.1251640	
.1251840	.12518
	.12520
.16014	
.16016	
.1601632	
.16018	.16018
.16020	
	.16022

Řezné podmínky / Cutting conditions / Schnittbedingungen / Условия резания

Material	A _p	A _e	V _c	f _z (mm/z)				
				Ø 50	Ø 80	Ø 100	Ø 160	
720373								
P.1	≤ 600 N/mm ²	0,1xD	1xb	30	0,050	0,070	0,080	0,090
P.2	≤ 850 N/mm ²	0,1xD	1xb	26	0,050	0,070	0,080	0,090
K.1	< 240 HB	0,1xD	1xb	25	0,050	0,070	0,080	0,090
N.4	≤ 800 N/mm ²	0,1xD	1xb	50-90	0,050	0,070	0,080	0,090
N.2	Si ≤ 12%	0,1xD	1xb	140-240	0,065	0,091	0,104	0,117
730373								
P.2	≤ 850 N/mm ²	0,1xD	1xb	26	0,050	0,070	0,080	0,090
P.4	≤ 900 N/mm ²	0,1xD	1xb	20	0,050	0,070	0,080	0,090
K.2	> 240 HB	0,1xD	1xb	17	0,050	0,070	0,080	0,090