

MULTIPLE FLUTES - TAPER ENDMILLS for RIB PROCESSING

- Rigid taper end mill for highly productive rib processing.
- Can also be used for side milling operation.

■ Taper Tolerance : $\pm 10'$

TPRE4...-150 series



EDP. No.	Dia.	θ	L ₁	L ₂	D ₂	STOCK
TPRE4004-02-150	0.4	1°30'	2	40	4	
TPRE4004-03-150			3			
TPRE4004-04-150			4			
TPRE4005-04-150	0.5	1°30'	4	40	4	
TPRE4005-06-150			6			
TPRE4006-04-150	0.6	1°30'	4	40	4	
TPRE4006-06-150			6			
TPRE4007-06-150	0.7	1°30'	6	40	4	
TPRE4007-08-150			8			
TPRE4008-06-150	0.8	1°30'	6	45	4	
TPRE4008-08-150			8			
TPRE4008-10-150			10			
TPRE4009-06-150	0.9	1°30'	6	45	4	
TPRE4009-08-150			8			
TPRE4009-10-150			10			
TPRE4010-06-150	1.0	1°30'	6	45	4	
TPRE4010-08-150			8			
TPRE4010-10-150			10			
TPRE4010-12-150			12			
TPRE4010-16-150			16	50		
TPRE4012-06-150	1.2	1°30'	6	45	4	
TPRE4012-08-150			8			
TPRE4012-10-150			10			
TPRE4012-12-150			12			
TPRE4012-16-150			16	50		
TPRE4014-08-150	1.4	1°30'	8	45	4	
TPRE4014-12-150			12			
TPRE4014-16-150			16	50		

※ These tools are manufactured based on order received.

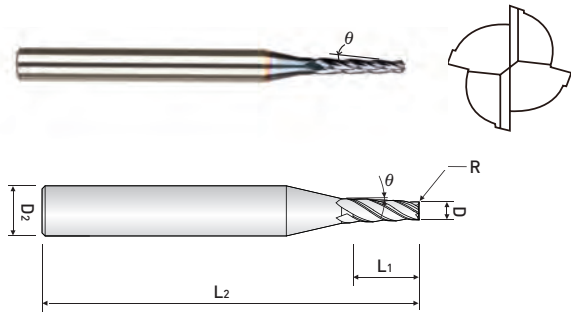

MULTIPLE FLUTES - TAPER ENDMILLS for RIB PROCESSING

- Rigid taper end mill for highly productive rib processing.
- Can also be used for side milling operation.

■ Taper Tolerance : $\pm 10'$

TPRE4...-150 series



EDP. No.	Dia.	θ	L ₁	L ₂	D ₂	STOCK
TPRE4015-08-150	1.5	1°30'	8	45	4	
TPRE4015-10-150			10			
TPRE4015-12-150			12			
TPRE4015-16-150			16			
TPRE4015-20-150			20			
TPRE4016-08-150	1.6	1°30'	8	45	4	
TPRE4016-10-150			10			
TPRE4016-12-150			12			
TPRE4016-16-150			16			
TPRE4016-20-150			20			
TPRE4018-08-150	1.8	1°30'	8	45	4	
TPRE4018-10-150			10			
TPRE4018-12-150			12			
TPRE4018-16-150			16			
TPRE4018-20-150			20			
TPRE4020-10-150	2.0	1°30'	10	45	4	
TPRE4020-12-150			12			
TPRE4020-16-150			16			
TPRE4020-20-150			20			
TPRE4020-25-150			25			
TPRE4025-10-150	2.5	1°30'	10	45	4	
TPRE4025-12-150			12			
TPRE4025-16-150			16			
TPRE4025-20-150			20			
TPRE4025-25-150			25			
TPRE4025-30-150			30			
TPRE4030-25-150	3.0	1°30'	25	60	6	
TPRE4030-40-150			40	80		

※ These tools are manufactured based on order received.

■ Tolerance

Mill Dia. (mm)	Shank Dia.
0 ~ -0.03	h6

※ Items can be changed for quality improvement without notice.