

MULTIPLE FLUTES - TAPER ENDMILLS for RIB PROCESSING

- Rigid taper end mill for highly productive rib processing.
- Can also be used for side milling operation.

■ Taper Tolerance : $\pm 10'$

TPRE4...-075 series



EDP. No.	Dia.	θ	L ₁	L ₂	D ₂	STOCK
TPRE4004-02-075	0.4	45'	2	40	4	
TPRE4004-03-075			3			
TPRE4004-04-075			4			
TPRE4005-04-075	0.5	45'	4	40	4	
TPRE4005-06-075			6			
TPRE4006-04-075	0.6	45'	4	40	4	
TPRE4006-06-075			6			
TPRE4007-06-075	0.7	45'	6	40	4	
TPRE4007-08-075			8			
TPRE4008-06-075	0.8	45'	6	45	4	
TPRE4008-08-075			8			
TPRE4008-10-075			10			
TPRE4009-06-075	0.9	45'	6	45	4	
TPRE4009-08-075			8			
TPRE4009-10-075			10			
TPRE4010-08-075	1.0	45'	8	45	4	
TPRE4010-10-075			10			
TPRE4010-12-075			12			
TPRE4012-08-075	1.2	45'	8	45	4	
TPRE4012-10-075			10			
TPRE4012-12-075			12			
TPRE4012-16-075			16	50		
TPRE4015-08-075	1.5	45'	8	45	4	
TPRE4015-10-075			10			
TPRE4015-12-075			12			
TPRE4015-16-075			16	50		
TPRE4015-20-075			20	55		

※ These tools are manufactured based on order received.

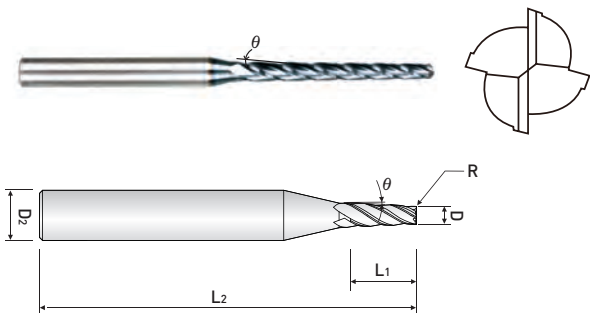

MULTIPLE FLUTES - TAPER ENDMILLS for RIB PROCESSING

- Rigid taper end mill for highly productive rib processing.
- Can also be used for side milling operation.

■ Taper Tolerance : $\pm 10'$

TPRE4...-075 series



EDP. No.	Dia.	θ	L ₁	L ₂	D ₂	STOCK
TPRE4016-08-075	1.6	45°	8	45	4	
TPRE4016-10-075			10			
TPRE4016-12-075			12			
TPRE4016-16-075			16			
TPRE4016-20-075			20			
TPRE4018-08-075	1.8	45°	8	45	4	
TPRE4018-10-075			10			
TPRE4018-12-075			12			
TPRE4018-16-075			16			
TPRE4018-20-075			20			
TPRE4020-10-075	2.0	45°	10	45	4	
TPRE4020-12-075			12			
TPRE4020-16-075			16			
TPRE4020-20-075			20			
TPRE4020-25-075			25			
TPRE4025-10-075	2.5	45°	10	45	4	
TPRE4025-12-075			12			
TPRE4025-16-075			16			
TPRE4025-20-075			20			
TPRE4025-25-075			25			
TPRE4025-30-075			30			
TPRE4030-25-075	3.0	45°	25	55	4	
TPRE4030-40-075			40	80	6	

※ These tools are manufactured based on order received.

■ Tolerance

Mill Dia. (mm)	Shank Dia.
0 ~ -0.03	h6

※ Items can be changed for quality improvement without notice.