

MULTIPLE FLUTES - TAPER ENDMILLS for RIB PROCESSING

- Rigid taper end mill for highly productive rib processing.
- Can also be used for side milling operation.
- Taper Tolerance : $\pm 10'$

TPRE4...-050 series



EDP. No.	Dia.	θ	L ₁	L ₂	D ₂	STOCK
TPRE4004-02-050	0.4	30°	2	40	4	
TPRE4004-03-050			3			
TPRE4004-04-050			4			
TPRE4005-02-050	0.5	30°	2	40	4	
TPRE4005-04-050			4			
TPRE4005-06-050			6			
TPRE4006-04-050	0.6	30°	4	40	4	
TPRE4006-06-050			6			
TPRE4007-06-050	0.7	30°	6	40	4	
TPRE4007-08-050			8			
TPRE4008-06-050	0.8	30°	6	45	4	
TPRE4008-08-050			8			
TPRE4008-10-050			10			
TPRE4009-06-050	0.9	30°	6	45	4	
TPRE4009-08-050			8			
TPRE4009-10-050			10			
TPRE4010-06-050	1.0	30°	6	45	4	
TPRE4010-08-050			8			
TPRE4010-10-050			10			
TPRE4010-12-050			12			
TPRE4010-16-050			16	50		
TPRE4012-06-050	1.2	30°	6	45	4	
TPRE4012-08-050			8			
TPRE4012-10-050			10			
TPRE4012-12-050			12			
TPRE4012-16-050			16	50		
TPRE4014-08-050	1.4	30°	8	45	4	
TPRE4014-12-050			12			
TPRE4014-16-050			16	50		

※ These tools are manufactured based on order received.

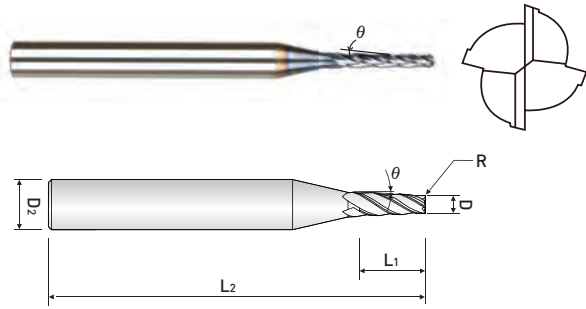

MULTIPLE FLUTES - TAPER ENDMILLS for RIB PROCESSING

- Rigid taper end mill for highly productive rib processing.
- Can also be used for side milling operation.

■ Taper Tolerance : $\pm 10'$

TPRE4...-050 series



EDP. No.	Dia.	θ	L ₁	L ₂	D ₂	STOCK
TPRE4015-08-050	1.5	30'	8	45	4	
TPRE4015-10-050			10			
TPRE4015-12-050			12			
TPRE4015-16-050			16			
TPRE4015-20-050			20			
TPRE4016-08-050	1.6	30'	8	45	4	
TPRE4016-10-050			10			
TPRE4016-12-050			12			
TPRE4016-16-050			16			
TPRE4016-20-050			20			
TPRE4018-08-050	1.8	30'	8	45	4	
TPRE4018-10-050			10			
TPRE4018-12-050			12			
TPRE4018-16-050			16			
TPRE4018-20-050			20			
TPRE4020-10-050	2.0	30'	10	45	4	
TPRE4020-12-050			12			
TPRE4020-16-050			16			
TPRE4020-20-050			20			
TPRE4020-25-050			25			
TPRB4025-10-150	2.5	30'	10	45	4	
TPRB4025-12-150			12			
TPRB4025-16-150			16			
TPRB4025-20-150			20			
TPRB4025-25-150			25			
TPRB4025-30-150			30			

※ These tools are manufactured based on order received.

■ Tolerance

Mill Dia. (mm)	Shank Dia.
0 ~ -0.03	h6

※ Items can be changed for quality improvement without notice.