

MULTIPLE FLUTES – TAPER BALL ENDMILLS for RIB PROCESSING

- Applying high hardened taper angle on the tool leads to highly efficient Rib processing
- Suitable to do machining performance on the inclined workpiece for electricity and electronic precise mold
- Taper Tolerance : $\pm 10'$

TPRB4...-100 series



EDP. No.	R	θ	L ₁	L ₂	D ₂	STOCK
TPRB4006-04-100	0.3	1°00'	4	40	4	
TPRB4006-06-100			6			
TPRB4008-06-100	0.4	1°00'	6	45	4	
TPRB4008-08-100			8			
TPRB4008-10-100			10			
TPRB4010-06-100	0.5	1°00'	6	45	4	
TPRB4010-08-100			8			
TPRB4010-10-100			10			
TPRB4010-12-100			12			
TPRB4010-16-100			16			
TPRB4012-06-100	0.6	1°00'	6	45	4	
TPRB4012-08-100			8			
TPRB4012-10-100			10			
TPRB4012-12-100			12			
TPRB4012-16-100			16			
TPRB4015-08-100	0.75	1°00'	8	45	4	
TPRB4015-10-100			10			
TPRB4015-12-100			12			
TPRB4015-16-100			16			
TPRB4015-20-100			20			
TPRB4016-08-100	0.8	1°00'	8	45	4	
TPRB4016-10-100			10			
TPRB4016-12-100			12			
TPRB4016-16-100			16			
TPRB4016-20-100			20			
TPRB4018-08-100	0.9	1°00'	8	45	4	
TPRB4018-10-100			10			
TPRB4018-12-100			12			
TPRB4018-16-100			16			
TPRB4018-20-100			20			

※ These tools are manufactured based on order received.

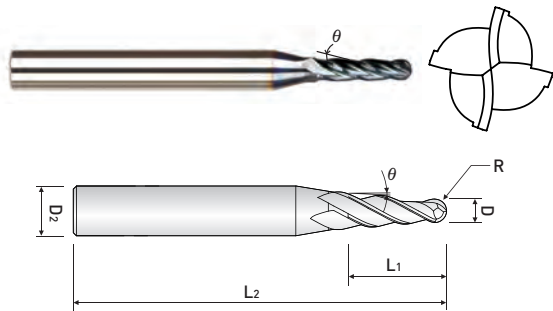

MULTIPLE FLUTES – TAPER BALL ENDMILLS for RIB PROCESSING

- Applying high hardened taper angle on the tool leads to highly efficient Rib processing
- Suitable to do machining performance on the inclined workpiece for electricity and electronic precise mold

■ Taper Tolerance : $\pm 10'$

TPRB4...-100 series



EDP. No.	R	θ	L ₁	L ₂	D ₂	STOCK
TPRB4020-10-100	1.0	1°00'	10	45	4	
TPRB4020-12-100			12			
TPRB4020-16-100			16	50		
TPRB4020-20-100			20	55		
TPRB4020-25-100			25			
TPRB4025-10-100	1.25	1°00'	10	45	4	
TPRB4025-12-100			12			
TPRB4025-16-100			16	50		
TPRB4025-20-100			20	55		
TPRB4025-25-100			25			

※ These tools are manufactured based on order received.

■ Tolerance

Radius (mm)	Shank Dia.
$\pm 0,01$	h6

※ Items can be changed for quality improvement without notice.