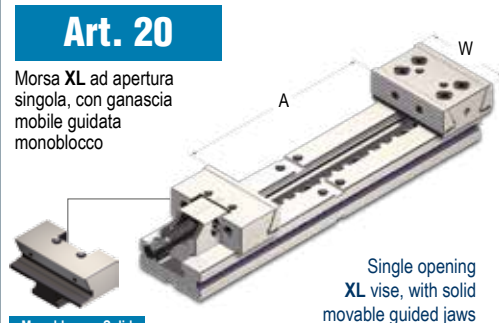

2

Tipo (grandezza) morsa / Vise (type) size	kN	1		2		3		4	
		16 kN	25 kN	30 kN	30 kN	400	500	600	700
Apertura massima / Maximum spread	A	290	320	360	460	400	500	600	700
	W	100	125	150			175		
	B	30	40	50			60		
	C	35	40	50			58		
	D	460	520	580	680	666	766	866	966
	G	75	95	125			145		
	kg	10	17	32	35	47	52	56	61
	Cod.	3.21.00000	3.22.10000	3.23.20000	3.23.30000	3.24.20000	3.24.30000	3.24.40000	3.24.50000

AMPLIA LE TUE APPLICAZIONI TRAMITE GLI ACCESSORI MODULARI !

Art. 313	Cod.	4.31.31000	4.31.32000	4.31.33000	4.31.34000
Piastre magnetiche parallele piane Magnetic parallel plates	H	23	33	43	53

Art. 212	Cod.	1.21.21000	1.21.22000	1.21.23000	1.21.24000
Ganascia mobile intermedia (da usare con Art. 313) Intermediate movable jaw (to be used with Art. 313)	H				

Art. 217	Cod.	2.21.71000	2.21.72000	2.21.73000	2.21.74000
Ganascia mobile prismatica Prismatic movable jaw					

Art. 242G	Cod.	1.24.2G100	1.24.2G200	1.24.2G300	1.24.2G400
Piastra ganascia con inserti GRIP Jaw plate with GRIP inserts					

Art. 271	Cod.	2.27.11000	2.27.12000	2.27.13000	2.27.14000
Supporto di serraggio con cilindro idraulico Clamping support with hydraulic cylinder					

Art. 391	Cod.	4.39.11000	4.39.12000	4.39.13000	4.39.14000
CNC / CNC					

Art. 392	Cod.	4.39.21000	4.39.22000	4.39.23000	4.39.24000
Pneumatico / Air control					

 Servocomandi oleopneumatici (completi di 1 cilindro e supporto) per serraggi multipli **contemporanei** o **indipendenti**, da 2 a 6 morse. Vedi da pag. 4.36 a 4.47

- Dotazione standard:**
- 1 arresto laterale Art. 370
 - 1 coppia di tasselli di posizionamento Art. 297
(Standard per cava da 16 mm; altre dimensioni a richiesta senza variazione di prezzo)
 - 1 chiave a pipa Art. 375 ■ 1 chiave a "T" Art. 376

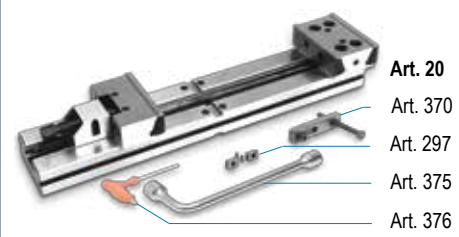

- Standard equipment:**
- 1 workstop Art. 370
 - 1 pair of positioning key-nuts Art. 297
(Standard for 16 mm slot. Other dimensions available on request without price change)
 - 1 box wrench Art. 375 ■ 1 T-wrench Art. 376

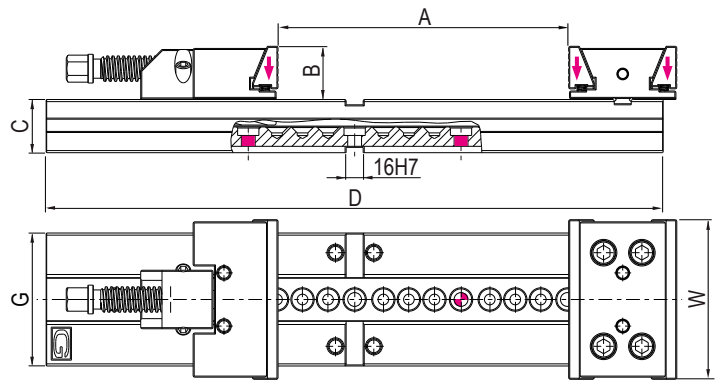
 Vedi gruppo 4 per gamma completa accessori
 See group 4 for complete range of accessories