

Gewindeschneid-Schnellwechselfutter mit Längenausgleich auf Druck und Zug

DIN 69871

Quick change tapping chucks *with* length compensation on compression and expansion

Mandrins de taraudage à changement rapide *avec* compensation longitudinale à la compression et traction



Verwendung:
Zur Aufnahme von Schnellwechsel-Einsätzen für Gewindebohrer.

Application:
For the chucking of quick change adaptors for taps.

Application:
Pour le serrage d'adaptateurs porte-tarauds à changement rapide.

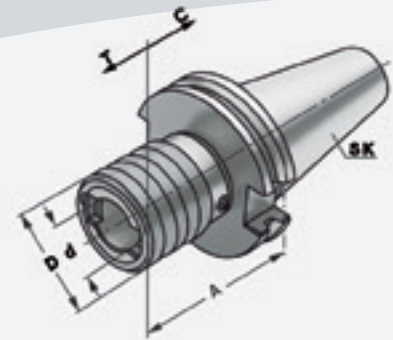

DIN 69871

Form A

G6,3
15.000 min⁻¹

CAD



Bestell-Nr. Order no. Référence	SK	Spannbereich Capacity Capacité	Größe Size Taille	A	D	d	T	C
302.16.12	SK 30	M3 – M14	1	65	36	19	7	7
302.16.20	SK 30	M5 – M22	2	99	53	31	12	12
402.16.12	SK 40	M3 – M14	1	59	36	19	7	7
402.16.20	SK 40	M5 – M22	2	97	53	31	12	12
402.16.36	SK 40	M14 – M36	3	156	78	48	17,5	17,5
502.16.12	SK 50	M3 – M14	1	63	36	19	7	7
502.16.20	SK 50	M5 – M22	2	97	53	31	12	12
502.16.36	SK 50	M14 – M36	3	140	78	48	17,5	17,5

Hinweis: Für Bearbeitungszentren ohne Synchronspindel.
Note: For machining centres without synchronous spindle.
Observation: Pour centres d'usinage sans broche synchrone.



9.29



9.30



9.35



9.23