

REVOLVING CENTER CNC HEAVY DUTY - R MODEL EXTENDED POINT

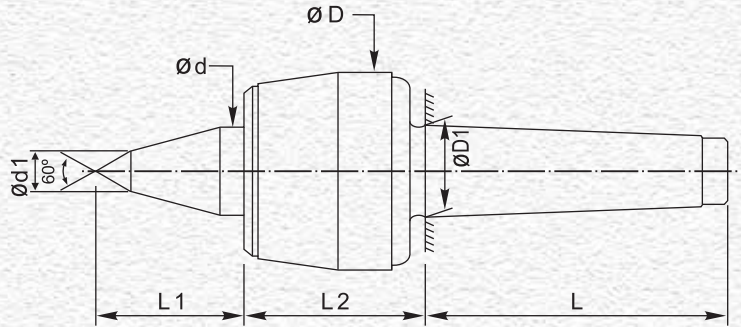

Part No.	Shank Taper	Point Style	Ød1 mm	Ød mm	ØD mm	ØD1 mm	L1 mm	L2 mm	L mm	Max. Job Wt. Kg.	Conc. Error mm	Max. RPM
HSC MT2 CNC HDRE	MT-2	Extended Point	10	20	46	17.780	35.0	48.5	64.0	140	0.005	7000
HSC MT3 CNC HDRE	MT-3	Extended Point	12	28	62	23.825	51.0	62.5	81.0	400	0.005	5000
HSC MT4 CNC HDRE	MT-4	Extended Point	14	32	68	31.267	54.5	65.0	102.5	500	0.005	3800
HSC MT5 CNC HDRE	MT-5	Extended Point	16	38	87	44.399	65.0	80.5	129.5	1200	0.005	3000
HSC MT6 CNC HDRE	MT-6	Extended Point	18	55	112	63.348	95.0	106.0	182.0	2500	0.010	2600