

The effective neck length shown is not an exact value and to avoid contact with the workpiece, we recommend the user control the precise value of this length.

ZSLNS40....-.. series



EDP. No.	Dimension(mm)						Effective Neck Length					STOCK	
	D	L ₂	L ₁	d ₁	L ₃	d ₃	θ	0.5°	1°	1.5°	2°		3°
ZSLNS4010-4	1	4	1.5	0.96	50	4	7.7	5.1	5.5	5.8	6.1	6.6	•
ZSLNS4010-6		6					6.6	7.2	7.7	8.1	8.4	9.1	•
ZSLNS4010-8		8					5.7	9.4	9.9	10.4	10.7	11.4	•
ZSLNS4010-10		10					5.0	11.5	12.1	12.6	13.0	13.7	•
ZSLNS4015-4	1.5	4	2.25	1.44	50	4	7.2	5.2	5.5	5.9	6.2	6.7	•
ZSLNS4015-6		6					6.0	7.3	7.8	8.1	8.5	9.1	•
ZSLNS4015-8		8					5.1	9.4	10.0	10.4	10.8	11.5	•
ZSLNS4015-10		10					4.5	11.6	12.1	12.6	13.0	13.8	•
ZSLNS4015-12		12			4.0	13.7	14.3	14.8	15.3	16.1	•		
ZSLNS4015-14		14			3.6	15.8	16.5	17.0	17.5	18.7	•		
ZSLNS4015-16		16			3.3	17.9	18.6	19.2	19.7	-	•		
ZSLNS4015-18		18			3.0	20.0	20.7	21.3	21.9	-	•		
ZSLNS4015-20		20			2.8	22.0	22.9	23.5	24.1	-	•		
ZSLNS4015-25		25			2.4	27.3	28.1	28.8	30.0	-	•		
ZSLNS4020-4	2	4	3	1.92	50	4	6.5	5.3	5.6	5.9	6.2	6.7	•
ZSLNS4020-6		6					5.3	7.4	7.8	8.2	8.5	9.1	•
ZSLNS4020-8		8					4.5	9.5	10.0	10.4	10.8	11.5	•
ZSLNS4020-10		10					3.9	11.6	12.2	12.7	13.1	13.8	•
ZSLNS4020-12		12			3.4	13.7	14.3	14.9	15.3	16.1	•		
ZSLNS4020-14		14			3.1	15.8	16.5	17.0	17.5	18.8	•		
ZSLNS4020-16		16			2.8	17.9	18.6	19.2	19.7	-	•		
ZSLNS4020-18		18			2.6	20.0	20.8	21.4	21.9	-	•		
ZSLNS4020-20		20			2.4	22.1	22.9	23.5	24.1	-	•		
ZSLNS4020-25		25			2.0	27.3	28.2	28.9	-	-	•		
ZSLNS4020-30	30	1.7	32.5	33.4	34.4	-	-	•					
ZSLNS4025-8	2.5	8	3.75	2.4	50	4	3.7	9.6	10.1	10.5	10.9	11.5	•
ZSLNS4025-10		10					3.1	11.7	12.2	12.7	13.1	13.8	•
ZSLNS4025-12		12					2.7	13.8	14.4	14.9	15.3	-	•
ZSLNS4025-14		14					2.4	15.9	16.5	17.1	17.5	-	•
ZSLNS4025-16		16			2.2	18.0	18.7	19.2	19.7	-	•		
ZSLNS4025-18		18			2.0	20.1	20.8	21.4	-	-	•		
ZSLNS4025-20		20			1.8	22.1	22.9	23.5	-	-	•		
ZSLNS4025-25		25			1.5	27.3	28.2	-	-	-	•		
ZSLNS4025-30		30			1.3	32.6	33.5	-	-	-	•		

- No interference

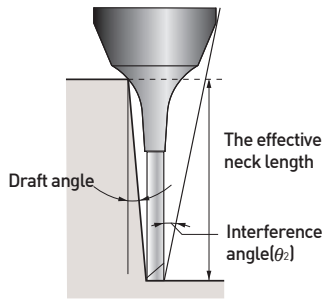

4 FLUTE, LONG NECK

- If the workpiece has draft angle, the interference length will be longer than the L_2 .
- Please refer to the effective neck length for the various draft angles.
- In addition, the angle at which the tool will interfere with the workpiece is shown as the "interference angle θ_2 ", and should also be referred to.

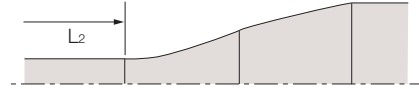

※The effective neck length shown is not an exact value and to avoid contact with the workpiece, we recommend the user control the precise value of this length.

EDP. No.	Dimension(mm)						Effective Neck Length					STOCK	
	D	L ₂	L ₁	d ₁	L ₃	d ₃	θ	0.5°	1°	1.5°	2°		3°
ZSLNS4030-8	3	8	4.5	2.88	55	6	5.6	9.6	10.1	10.5	10.9	11.5	•
ZSLNS4030-10		10					5.0	11.7	12.3	12.7	13.1	13.8	•
ZSLNS4030-12		12					4.5	13.8	14.4	14.9	15.4	16.3	•
ZSLNS4030-14		14			4.1		15.9	16.6	17.1	17.6	18.9	•	
ZSLNS4030-16		16			3.7		18.0	18.7	19.3	19.8	21.6	•	
ZSLNS4030-18		18			3.4		20.1	20.8	21.4	21.9	24.2	•	
ZSLNS4030-20		20			3.2		22.2	23.0	23.6	24.2	26.9	•	
ZSLNS4030-25		25			2.7		27.4	28.2	28.9	30.2	-	•	
ZSLNS4030-30		30			2.4		32.6	33.5	34.5	36.2	-	•	
ZSLNS4030-35		35			2.1		37.7	38.7	40.2	42.2	-	•	
ZSLNS4030-40		40			1.9		42.9	43.9	45.9	-	-	•	
ZSLNS4040-12		4			12		6	3.85	60	6	3.4	13.9	14.5
ZSLNS4040-16	16		2.8	18.1	18.8	19.3					19.8	-	•
ZSLNS4040-20	20		2.3	22.3	23.0	23.6					24.3	-	•
ZSLNS4040-25	25		2.0	27.4	28.3	28.9			-		-	•	
ZSLNS4040-30	30		1.7	32.6	33.5	34.6			-		-	•	
ZSLNS4040-35	35		1.5	37.8	38.8	-			-		-	•	
ZSLNS4040-40	40		1.3	42.9	44.0	-			-		-	•	
ZSLNS4040-45	45		1.2	48.1	49.4	-			-		-	•	
ZSLNS4040-50	50		1.1	53.2	54.8	-			-		-	•	
ZSLNS4050-16	5	16	7.5	4.85	60	6	1.5	18.1	18.8	-	-	-	•
ZSLNS4050-20		20					1.3	22.3	23.0	-	-	-	•
ZSLNS4050-25		25			1.1		27.4	28.3	-	-	-	•	
ZSLNS4050-30		30			0.9		32.6	-	-	-	-	•	
ZSLNS4050-35		35			0.8		37.8	-	-	-	-	•	
ZSLNS4050-40		40			0.7		42.9	-	-	-	-	•	
ZSLNS4050-40		40			0.7		42.9	-	-	-	-	•	
ZSLNS4050-50		50			0.6		53.2	-	-	-	-	•	

- No interference

■ Tolerance

Diameter	Mill Dia. (mm)	Shank Dia.
0,1 ~ 0,5	0 ~ -0,012	h5
0,6 ~ 4	0 ~ -0,015	

※Items can be changed for quality improvement without notice.