

MULTIPLE FLUTES - TAPER ENDMILLS for RIB PROCESSING

- Rigid taper end mill for highly productive rib processing.
- Can also be used for side milling operation.

■ Taper Tolerance : $\pm 10'$

TPRE4...-200 series



EDP. No.	Dia.	θ	L ₁	L ₂	D ₂	STOCK
TPRE4004-02-200	0.4	2°00'	2	40	4	
TPRE4004-03-200			3			
TPRE4004-04-200			4			
TPRE4005-04-200	0.5	2°00'	4	40	4	
TPRE4005-06-200			6			
TPRE4006-04-200	0.6	2°00'	4	40	4	
TPRE4006-06-200			6			
TPRE4007-06-200	0.7	2°00'	6	40	4	
TPRE4007-08-200			8			
TPRE4008-06-200	0.8	2°00'	6	45	4	
TPRE4008-08-200			8			
TPRE4008-10-200			10			
TPRE4009-06-200	0.9	2°00'	6	45	4	
TPRE4009-08-200			8			
TPRE4009-10-200			10			
TPRE4010-06-200	1.0	2°00'	6	45	4	
TPRE4010-08-200			8			
TPRE4010-10-200			10			
TPRE4010-12-200			12			
TPRE4010-16-200			16	50		
TPRE4012-06-200	1.2	2°00'	6	45	4	
TPRE4012-08-200			8			
TPRE4012-10-200			10			
TPRE4012-12-200			12			
TPRE4012-16-200			16	50		
TPRE4014-08-200	1.4	2°00'	8	45	4	
TPRE4014-12-200			12			
TPRE4014-16-200			16	50		

※ These tools are manufactured based on order received.

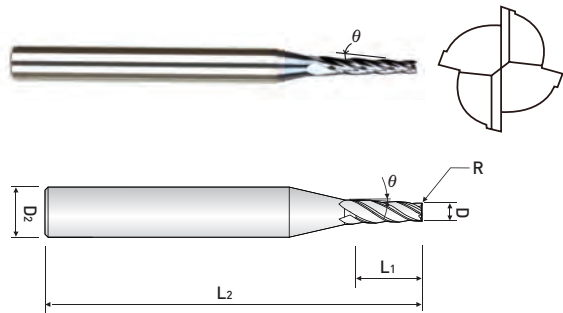

MULTIPLE FLUTES - TAPER ENDMILLS for RIB PROCESSING

- Rigid taper end mill for highly productive rib processing.
- Can also be used for side milling operation.
- Taper Tolerance : $\pm 10'$

TPRE4...-200 series



EDP. No.	Dia.	θ	L ₁	L ₂	D ₂	STOCK
TPRE4015-08-200	1.5	2°00'	8	45	4	
TPRE4015-10-200			10			
TPRE4015-12-200			12			
TPRE4015-16-200			16			
TPRE4015-20-200			20			
TPRE4016-08-200	1.6	2°00'	8	45	4	
TPRE4016-10-200			10			
TPRE4016-12-200			12			
TPRE4016-16-200			16			
TPRE4016-20-200			20			
TPRE4018-08-200	1.8	2°00'	8	45	4	
TPRE4018-10-200			10			
TPRE4018-12-200			12			
TPRE4018-16-200			16			
TPRE4018-20-200			20			
TPRE4020-10-200	2.0	2°00'	10	45	4	
TPRE4020-12-200			12			
TPRE4020-16-200			16			
TPRE4020-20-200			20			
TPRE4020-25-200			25			
TPRE4025-10-200	2.5	2°00'	10	45	4	
TPRE4025-12-200			12			
TPRE4025-16-200			16			
TPRE4025-20-200			20	55	6	
TPRE4025-25-200			25	60		
TPRE4025-30-200			30	65		
TPRE4030-25-200	3.0	2°00'	25	60	6	
TPRE4030-40-200			40	80		

※ These tools are manufactured based on order received.

■ Tolerance

Mill Dia. (mm)	Shank Dia.
0 ~ -0.03	h6

※ Items can be changed for quality improvement without notice.