

MULTIPLE FLUTES - TAPER ENDMILLS for RIB PROCESSING

- Rigid taper end mill for highly productive rib processing.
- Can also be used for side milling operation.

■ Taper Tolerance : $\pm 10'$

TPRE4...-100 series



EDP. No.	Dia.	θ	L ₁	L ₂	D ₂	STOCK
TPRE4004-02-100	0.4	1°00'	2	40	4	
TPRE4004-03-100			3			
TPRE4004-04-100			4			
TPRE4005-02-100	0.5	1°00'	2	40	4	
TPRE4005-04-100			4			
TPRE4005-06-100			6			
TPRE4006-04-100	0.6	1°00'	4	40	4	
TPRE4006-06-100			6			
TPRE4007-06-100	0.7	1°00'	6	40	4	
TPRE4007-08-100			8			
TPRE4008-06-100	0.8	1°00'	6	45	4	
TPRE4008-08-100			8			
TPRE4008-10-100			10			
TPRE4009-06-100	0.9	1°00'	6	45	4	
TPRE4009-08-100			8			
TPRE4009-10-100			10			
TPRE4010-06-100	1.0	1°00'	6	45	4	
TPRE4010-08-100			8			
TPRE4010-10-100			10			
TPRE4010-12-100			12			
TPRE4010-16-100			16	50		
TPRE4012-06-100	1.2	1°00'	6	45	4	
TPRE4012-08-100			8			
TPRE4012-10-100			10			
TPRE4012-12-100			12			
TPRE4012-16-100			16	50		
TPRE4014-08-100	1.4	1°00'	8	45	4	
TPRE4014-12-100			12			
TPRE4014-16-100			16	50		

※ These tools are manufactured based on order received.

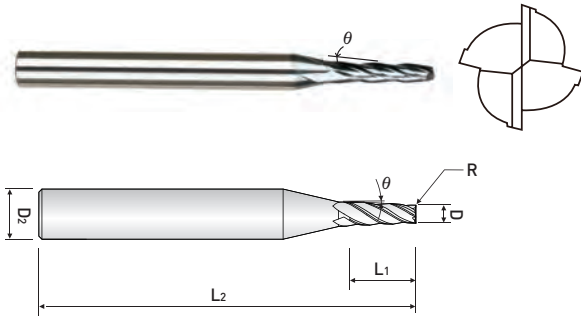

MULTIPLE FLUTES - TAPER ENDMILLS for RIB PROCESSING

- Rigid taper end mill for highly productive rib processing.
- Can also be used for side milling operation.

■ Taper Tolerance : $\pm 10'$

TPRE4...-100 series



EDP. No.	Dia.	θ	L ₁	L ₂	D ₂	STOCK
TPRE4015-08-100	1.5	1°00'	8	45	4	
TPRE4015-10-100			10			
TPRE4015-12-100			12			
TPRE4015-16-100			16			
TPRE4015-20-100			20			
TPRE4016-08-100	1.6	1°00'	8	45	4	
TPRE4016-10-100			10			
TPRE4016-12-100			12			
TPRE4016-16-100			16			
TPRE4016-20-100			20			
TPRE4018-08-100	1.8	1°00'	8	45	4	
TPRE4018-10-100			10			
TPRE4018-12-100			12			
TPRE4018-16-100			16			
TPRE4018-20-100			20			
TPRE4020-10-100	2.0	1°00'	10	45	4	
TPRE4020-12-100			12			
TPRE4020-16-100			16			
TPRE4020-20-100			20			
TPRE4020-25-100			25			
TPRE4025-10-100	2.5	1°00'	10	45	4	
TPRE4025-12-100			12			
TPRE4025-16-100			16			
TPRE4025-20-100			20			
TPRE4025-25-100			25			
TPRE4025-30-100			30			
TPRE4030-25-075	3.0	1°00'	25	55	4	
TPRE4030-40-075			40	80	6	

※ These tools are manufactured based on order received.

■ Tolerance

Mill Dia. (mm)	Shank Dia.
0 ~ -0.03	h6

※ Items can be changed for quality improvement without notice.