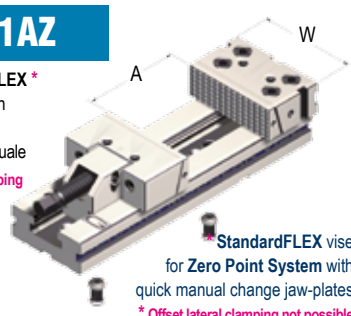
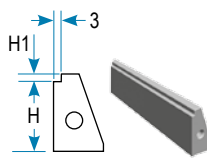

Tipo (grandezza) morsa / Vise type (size)	kN	1		2		3		4	
		16 kN	25 kN	30 kN	30 kN	30 kN	30 kN	30 kN	30 kN
Apertura massima / Maximum spread	A	100	150	200	300	200	300	400	500
<b>Art. 1AZ</b> Morsa <b>StandardFLEX</b> * per <b>Zero Point</b> con piastre ganasce a cambio rapido manuale * Offset lateral clamping not possible.	W	96	121	146		171			
	B	28	38	48		58			
	C	35	40	50		58			
	D	270	345	420	520	455	555	655	755
	G	75	95	125		145			
	kg	7.3	13.2	26.2	29.7	37.9	43	48.1	53.2
	Cod.	1.1A.Z1000	1.1A.Z2000	1.1A.Z3200	1.1A.Z3300	1.1A.Z4200	1.1A.Z4300	1.1A.Z4400	1.1A.Z4500

**AMPLIA LE TUE APPLICAZIONI TRAMITE GLI ACCESSORI MODULARI !**
**Art. 230E**

 Piastra ganasce intercambiabile  
 Interchangeable jaw plate

Cod.	4.23.0E101	4.23.0E201	4.23.0E301	4.23.0E401
H	23	33	43	53
H1	5	5	5	5

**Art. 212**

 Ganasce mobile intermedia  
 (da usare con Art. 230E)

Intermediate movable jaw (to be used with Art. 230E)

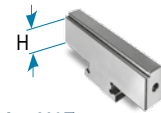

Cod.	1.21.21000	1.21.22000	1.21.23000	1.21.24000
------	------------	------------	------------	------------

**Art. 230B**

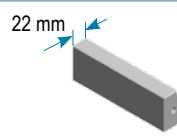
 Piastra ganasce intercambiabile dolce  
 Soft interchangeable jaw plate

Cod.	4.23.0B101	4.23.0B201	4.23.0B301	4.23.0B401
------	------------	------------	------------	------------

**Art. 230F**

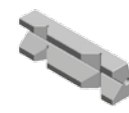
 Piastra ganasce intercambiabile prismatica  
 Prismatic interchangeable jaw plate

Cod.	4.23.0F101	4.23.0F201	4.23.0F301	4.23.0F401
------	------------	------------	------------	------------

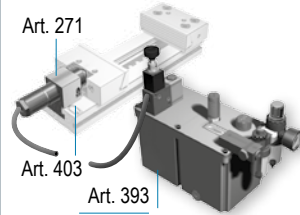
**Art. 391**

CNC / CNC

**Art. 392**

Pneumatico / Air control

Cod.	4.39.11000	4.39.12000	4.39.13000	4.39.14000
Cod.	4.39.21000	4.39.22000	4.39.23000	4.39.24000

 Servocomandi oleopneumatici (completi di 1 cilindro e supporto) per serraggi multipli **contemporanei** o **indipendenti**, da 2 a 6 morse. Vedi da pag. 4.36 a 4.47

**Dotazione standard:**

- 1 arresto laterale Art. 370
- 2 tiranti Art. 10A
- 2 tappi Art. 291
- 1 chiave a pipa Art. 375 ■ 1 chiave a "T" Art. 376

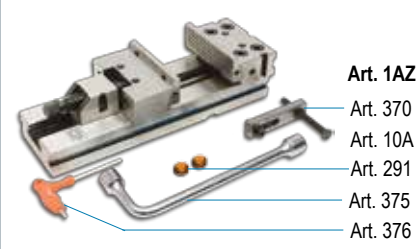
**Standard equipment:**

- 1 workshop Art. 370
- 2 pullstuds Art. 10A
- 2 inserts Art. 291
- 1 box wrench Art. 375 ■ 1 T-wrench Art. 376

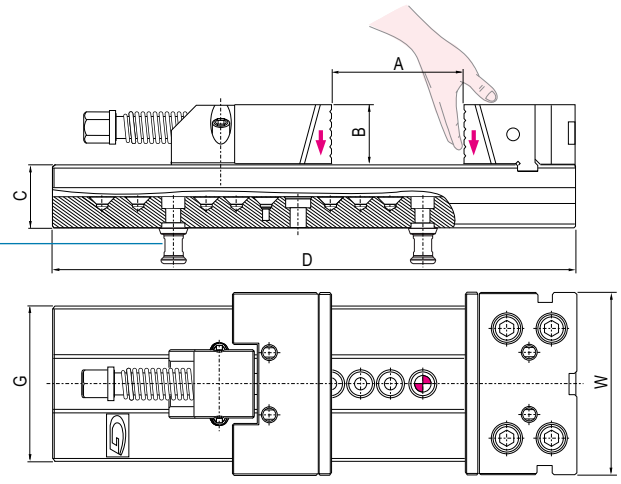
 Vedi gruppo 4 per gamma completa accessori  
 See group 4 for complete range of accessories